



# USER INSTRUCTIONS

## ***D20-series Compact Digital Positioner***

FCD PNENIM0020-06-A5 – 07/24

*Installation*

*Operation*

*Maintenance*



# Contents

---

<b>1. Introduction.....</b>	<b>3</b>	<b>8. Control.....</b>	<b>23</b>
<b>2. Warning.....</b>	<b>4</b>	D20 Single Button	23
Special Conditions for Safe Use	4	Calibration	23
Maintenance/service	5	Set of Direct or Reverse action	24
<b>3. Storage.....</b>	<b>6</b>	Show gain setting	24
<b>4. Description.....</b>	<b>7</b>	Change of gain setting	25
<b>5. Type sign example .....</b>	<b>8</b>	Factory reset, initial calibration of the 4-20mA	
<b>6. D20 Model code .....</b>	<b>9</b>	input and output signals and D20 calibration	26
<b>7. Installation .....</b>	<b>10</b>	To calibrate 4-20 mA input signal	26
Removal of cover	10	To calibrate 4-20 mA output signal	26
Air Preparation	10	D22 Menus and 5 Pushbuttons	27
Mounting	11	Menu indicator	28
Adapter drawing	12	Basic Menu	29
Suit shaft style "09"	12	Full Menu	38
For Linear actuator	13	<b>9. Maintenance/service .....</b>	<b>45</b>
Mounting the positioner	13	<b>10. Trouble shooting .....</b>	<b>50</b>
Mounting of the PMV D20 positioner on a linear		<b>11. Technical data.....</b>	<b>51</b>
pneumatic actuator	14	<b>12. Dimensional Drawing.....</b>	<b>53</b>
Mounting the stem clamp bracket and take-off		<b>13. Spare parts .....</b>	<b>54</b>
arm	14	<b>14. Applied Standards .....</b>	<b>56</b>
Follower pin adjustment	15	<b>15. Control Drawing.....</b>	<b>57</b>
Rotary actuators	15	<b>16. Contact List.....</b>	<b>60</b>
Flowact direct mounting	16		
Mounting the PMV D20 positioner on a quarter-			
turn actuator (closed or open by spring)	17		
Rotary actuator VDI/VDE 3485 (Namur)	17		
Electrical connections	20		

# 1. Introduction

---

The D20-series is a digital positioner designed primarily for controlling modulating valves. The positioner can be used with single acting actuators with either rotary or linear movement.

The D20-series can be equipped with modules for limit switches and pressure gauges. The modules can be factory assembled before delivery or fitted later.

The modules for limit switches can contain one of the following:

- Two mechanical contacts
- Two proximity switches
- Two inductive sensors

See page [20](#) and [47](#) for more options available



*Note!*

Only authorized technicians are allowed to work with certified products.



## 2. Warning

### ***Special Conditions for Safe Use***

The enclosure of PMV D20-series Intrinsically safe version is made of aluminium and any impact or friction caused by external objects shall be avoided in the application. Control Drawing D4-086C contains the parameters for intrinsic safety. The intrinsic safe circuits D20-series is insulated from earth and complies with the dielectric strength test of 500 V ac.

### ***Special Conditions for Safe Use (ATEX/IEC specific)***

The surface area of the plastic parts on the cover exceeds the limits specified in EN 60079-0 for II 1G (EPL Ga) for gas group IIC and intensive rubbing or brush charging should be avoided when used in an IIC explosive atmosphere.

In a hazardous environment where there is a risk of explosion, electrical connections must comply with the relevant regulations.

Do not disconnect equipment unless area is known to be non-hazardous. or; read, understand and adhere to the manufacturer's live maintenance procedures. To prevent ignition of flammable or combustible atmospheres, disconnect power before servicing,

Substitutions of components may impair suitability for hazardous (classified) locations.

### ***Special Conditions for Safe Use (FM specific)***

For Intrinsically Safe applications: Use linear barrier only.

Potential risk of sparking from aluminum alloy enclosure. In Division 1 or Zone 0 installations, equipment shall be installed in such manner as to prevent the possibility of sparks resulting from friction or impact against the enclosure.

Potential risk of electrostatic sparking. Clean only with a damp cloth.

### ***Environmental requirements***

Some switch options may decrease the temperature working range see Control Drawing D4-086C for details.



## ***Maintenance/service***

### ***Warning!***

When upgrading electronically parts inside a PMV positioner approved for installation in Hazardous locations special procedures apply, permission from PMV/Flowserve is required prior to the start of work. Please contact a Flowserve office for information regarding proper procedures.

www.pmv.nu or infopmv@flowserve.com

### ***Warning!***

Always turn off the air and electrical supplies before starting any work.

Always turn off the air and electrical supplies (input signals) when shutting down the PMV positioner for any purpose.

## ***General safety***

### ***Safety instruction***

Read the safety instructions in this manual carefully before using the product. The installation, operation, and maintenance of the product must be done by staff with the necessary training and experience. If any questions arise during installation, contact the supplier/sales office before continuing work.

### ***Warning***

The valve can open or close very quickly when in operation and, if handled incorrectly, may cause damages to fingers. There may also be unintentional effects due to it fully opening or shutting off the flow in the process pipe. Please note the following:

- If the input signal fails or is switched off, the valve operates quickly to its default position.
- If the compressed air supply fails or is turned off, rapid movements can occur.
- The valve is not controlled by the input signals when in the Out of Service mode. It will open/ close in the event of an internal or external leak.
- If a high value is set for Cut off, fast movements can occur.
- When the valve is controlled in the Manual mode, the valve can operate quickly.
- Incorrect settings can cause self-oscillation, which can lead to damage.

### ***Important***

- Always turn off the compressed air supply before removing or disconnecting the air supply connection or the integral filter. Remove or disconnect with care as air connection "C-" is still under pressure even after the air supply is turned off.
- Always work in an ESD (Electrostatic Discharge) protected area when servicing the Printed circuit boards (PCB's). Make sure the input signal is switched off.
- The air supply must be free from moisture, water, oil and particles according to DIN/ISO 8573-1-2001 3.2.3
- Failure to comply with instructions specified in this IOM leads to warranty void.

### 3. Storage

---

*General*

The D20-series positioner is a precision instrument. Therefore, it is essential that it is handled and stored in the correct way. Always follow the instructions in this IOM!

*Note:* As soon as the positioner is connected and started, internal air venting will provide protection against corrosion and prevent the ingress of moisture. For this reason, the air supply pressure should always be kept on unless repair/maintenance work of the positioner, actuator or valve equipment is in progress.

*Storage indoors*

Store the positioner in its original packaging. The storage environment must be clean, dry, and cool (Temp -15°C to 25°C, 5°F to 77°F).

*Storage outdoors or for a longer period*

If the positioner must be stored outdoors, it is important that all the cover screws are tightened and that all open ports/connections are properly sealed and/or plugged.

The red shipping plugs are not intended as a permanent outdoor plug. The unit should be packed with a desiccant (silica gel) in a plastic bag or similar, covered with plastic, and not exposed to sunlight, rain, or snow.

## 4. Description

---

PMV D20-series is a compact digital positioner that suits both linear and rotary actuators. It's modular and flexible design allows mounting according to the both standard VDI/VDE 3845 for rotary and IEC 534-6 & Flowtop for linear actuators with integrated tubing.

Further on, PMV D20/D22 offers feedback capability with optional plug in switches, HART communication and auto calibration for simple and trouble free commissioning.



## 5. Type sign example

---

Logotype		Type and Model code	
Certification Statement		Input Pressure:	
	Additional warnings, and installation information		Input Signal:
			Temp Range:
Certificate name		Ingress protection	
Special note		Manufacturer	
Area for switch type and terminals			
Communication protocol		Bar Code	
Software:	Prod.year:	S/N:	

### *Ratings and Marking*

*D20 ATEX/IEC certification temperature range and marking:*

II 1 G Ex ia IIC T4 Ta -20°C to 85°C Ga

*D20 US/CA FM certification FM18US0180X and FM18CA0082X marking:*

IS Cl. I Div.1 Gr. A-D T4

Cl. I Zone 0 AEx/Ex ia IIC T4 Ga

Cl. I Div.2 Gr. A-D T4

Cl. I Zone 2 IIC T4 (US Only)

*Listing Company :*

PMV Automation AB

Korta Gatan 9

SE-171 54 SOLNA

SWEDEN



## 6. D20 Model code

<b>A = Model no</b>		
D20	Single button interface, LED status	<input type="checkbox"/>
D21	Single button interface, LED status and LCD	<input type="checkbox"/>
D22	Full LCD menu, 5 button UI, LED status	<input type="checkbox"/>
<b>B = Approval, Certificate</b>		
D	General purpose version	<input type="checkbox"/>
A	Intrinsically Safe Ex ia ATEX	<input type="checkbox"/>
B	Intrinsically Safe Ex ia INMETRO	<input type="checkbox"/>
N	Intrinsically Safe Ex ia CCC	<input type="checkbox"/>
M	Intrinsically Safe Ex ia CCOE	<input type="checkbox"/>
F	Intrinsically Safe Ex ia FM	<input type="checkbox"/>
<b>C = Function</b>		
S	SA D20 E/P (poppet valve)	<input type="checkbox"/>
<b>D = Connections Air, Electrical</b>		
M	1/4" NPT air, M20x1,5 electrical	<input type="checkbox"/>
N	1/4" NPT air, 1/2"NPT electrical	<input type="checkbox"/>
<b>E = Connection feature</b>		
2	2 Electrical conduits	<input type="checkbox"/>
T	2 Electrical conduits, threaded Aux. ventilation	<input type="checkbox"/>
<b>F = Housing material/ Surface treatment</b>		
U	Aluminium/Powder coating	<input type="checkbox"/>
<b>G = Mounting options / Shaft</b>		
0 9	Double D type, adaptor spindle	<input type="checkbox"/>
1 2	Flowtop, direct mounting, D4-As909m(D20) included	<input type="checkbox"/>
2 3	VDI/VDE 3845 rotary, Mounting kit not included	<input type="checkbox"/>
3 0	Adaptor shaft, select between 01/06/26/30/36/02/43	<input type="checkbox"/>
3 9	IEC 534-6, Flat D type, nut incl. Mounting kit not included	<input type="checkbox"/>
<b>H = Cover and Indicator</b>		
P V A	PMV, Black cover, Arrow indicator	<input type="checkbox"/>
P V B	PMV, Black cover, No indicator	<input type="checkbox"/>
F W A	Flowserve, White, Arrow indicator	<input type="checkbox"/>
F W B	Flowserve, White, No indicator	<input type="checkbox"/>
<b>I = Temperature/seals</b>		
Z	-20°C to 85°C (-4°F to 185°F)	<input type="checkbox"/>
<b>J = Input signal/Protocol</b>		
4	4-20 mA / none	<input type="checkbox"/>
5	4-20 mA, / HART	<input type="checkbox"/>
P	Profibus PA	<input type="checkbox"/> (Not when K=T)
F	Foundation Fieldbus	<input type="checkbox"/> (Not when K=T)
<b>K = Feedback option, switches</b>		
X	No feedback option	<input type="checkbox"/>
T	4-20 mA transmitter only (J = 4,5)	<input type="checkbox"/>
S	Limit switches Mechanical SPDT	<input type="checkbox"/>
N	Namur V3 type sensor, P+F NJ2-V3-N	<input type="checkbox"/>
P	Limit switches Proximity SPDT	<input type="checkbox"/>
5	Slot type Namur sensor, P+F SJ2-SN	<input type="checkbox"/>
6	Slot type Namur sensor, P+F SJ2-N	<input type="checkbox"/>
<b>L = Options, Add in electronics</b>		
0	No pressure sensors	<input type="checkbox"/>
<b>M = Accessories</b>		
X	No accessories	<input type="checkbox"/>
N	Gauge block 1/4" NPT (2 gauges included)	<input type="checkbox"/>
<b>N = Special Options</b>		
N	No special options	<input type="checkbox"/>

**A A A B C D E - F G G H H H - I J K L M N**

For latest version of valid model code please see [www.pmv.nu](http://www.pmv.nu)

## 7. Installation

### **Removal of cover**

*General purpose / Intrinsically safe*

Remove cover by first loosening the screw 1 and then the two screws 2.

To install cover, first tighten the screw 1, then the two screws 2.

Tighten to 1.5 Nm  $\pm$  15%.



### **Air Preparation**

Supply air should meet requirements specified on [page 5](#). A coalescing filter/regulator should be installed in front of the supply air connection. Connect the air supply to the filter, which is connected to the D20 positioner.

### **Tubing**

It is recommended to use tubes with a minimum inner diameter of  $\varnothing$  6 mm (1/4").

### **Air supply requirements**

*Poor quality air supply is the main cause of problems in pneumatic systems.*

The air supply must be free from moisture, water, oil and particles and delivered @ 1.4-6 barg (20-85 psi)

Standard: *DIN/ISO 8573-1-2001 3.2.3*

Filtered to 5 Micron, dew point -40°C/F

Oil 1mg/m<sup>3</sup> (0,83 ppm by weight)

The air must come from a refrigeration dried supply or be treated in such a way that its dew point is at least 10°C (18°F) below the lowest expected ambient temperature.

Before the air supply is connected to the positioner, we recommend the pipe/tube is opened freely for 2 to 3 minutes to allow any contamination to be blown out. Direct the air jet into a large paper bag to trap any water, oil, or other foreign materials. If this indicates that the air system is contaminated, it should be properly cleaned before continuing.

	<p><b>WARNING!</b> Do not direct the open air jet towards people or objects because it may cause personal injury or damage.</p>
---	---

**Mounting**

*Note:* If the positioner is installed in a hazardous environment, it must be of a type approved for this purpose.

All versions of the D20 positioner have an ISO F05 footprint. The holes are used to attach the D20 to the mounting bracket B. Please contact PMV or your local distributor representative with actuator specifics for the proper mounting bracket and hardware.

The spindle shaft S09 can be used to suit various actuators in question by the use of adaptors.

It is important that the positioner's spindle shaft and the lever arms, that transfer the actuator movements, are correctly mounted. Any tension between these parts can cause incorrect operation and abnormal wear.

*Spindle shafts*

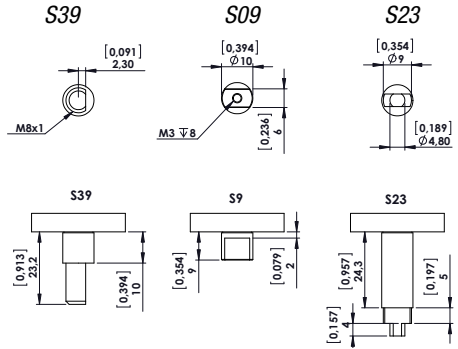

*Note:* There are many spindle options available depending on the actuator. Please contact your local PMV supplier for all options available.

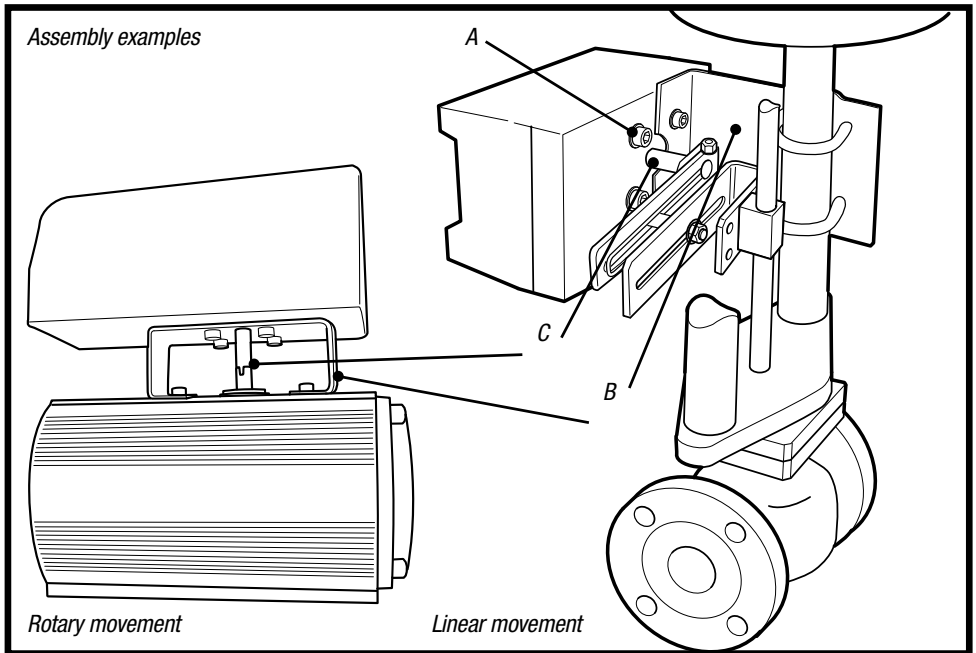

**Adapter drawing**  
**Suit shaft style "09"**

**S9 Adaptors**

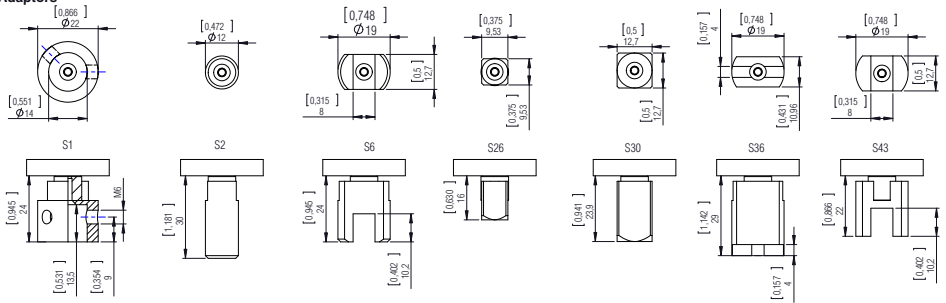

**For Linear actuator  
Mounting the positioner**

1. Adjust the actuator to mid-stroke.
2. Pre-assemble the mounting bracket on the left actuator leg hand-tight with two U-bolts, nuts and lockwashers.
3. Attach the positioner to the pre-assembled mounting bracket and fasten it with two hexagon head screws and two lock washers. Check that the follower pin is inserted in the slot of the take-off arm and the follower arm is positioned at a right angle to the outer edge of the positioner.
4. Tighten all screws and nuts.

*NOTE:* A slight unsymmetrical mounting increases the linearity deviation but does not affect the performance of the device. Depending on the actuator size and stroke it may be necessary to flip the take-off arm by 180° and attach it to the opposite side of the stem clamp bracket.

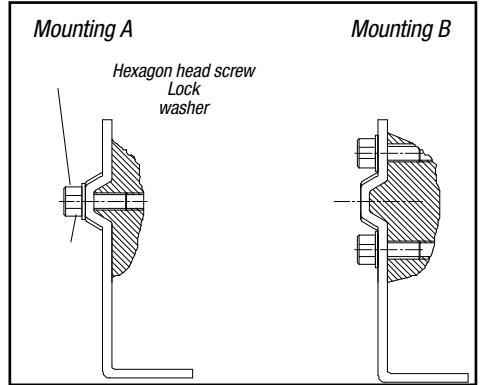

Yoke Actuator Mounting (according to IEC 534 part 6)

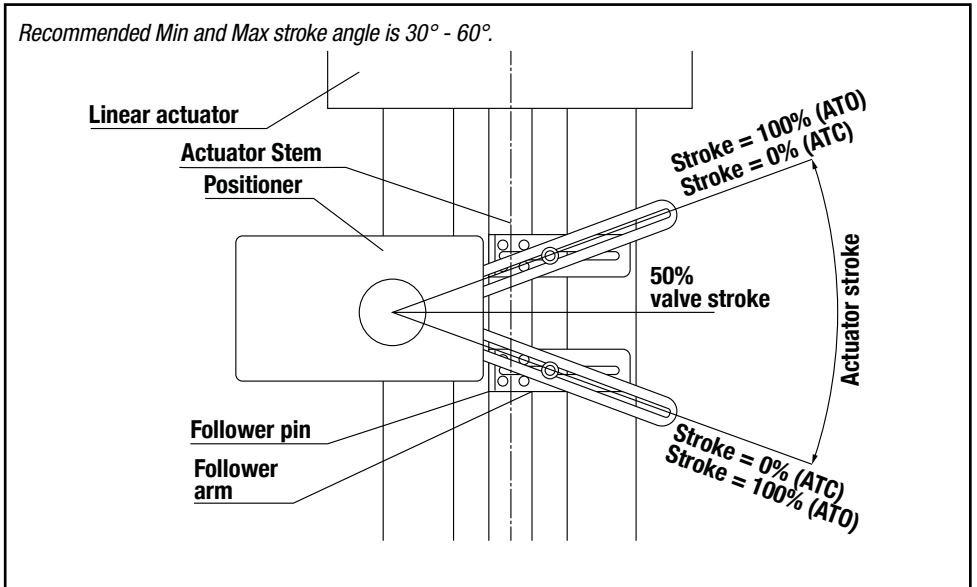

Basic Adjustment for a Linear Pneumatic Actuator

**Mounting of the PMV D20 positioner on a linear pneumatic actuator (NAMUR / IEC 534 part 6)**

The mounting of a rod actuator kit (according to IEC 534 part 6) is described in an example by using the following equipment:

**Valve:** Standard globe valve or equivalent

**Actuator:** Single-acting pneumatic actuator

**Positioner:** PMV D20 with mounting kit.

**Pre-assembly:** Valve with actuator (valve stroke is matched with the actuator stroke).

For mounting, proceed as follows:

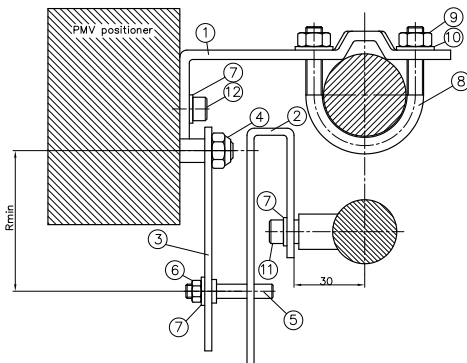

**Mounting the Follower Arm (Figures 1 and 2)**

1. Unscrew the lock nut for the follower arm attachment.
2. Place the follower arm on the shaft at the back of the positioner and fasten it with the lock nut. The follower pin should point back from the positioner.



**CAUTION:** Maximum torque 0,25 Nm (0,18 ft-lbs).

**Mounting the stem clamp bracket and take-off arm**

1. Attach the stem clamp bracket to the stem clamp and fasten it with two hexagon socket screws and lock washers.
2. Attach the take off arm to the stem clamp bracket and fasten it with a hexagon socket capscrew and a washer. Ensure the take-off arm slot is centered.

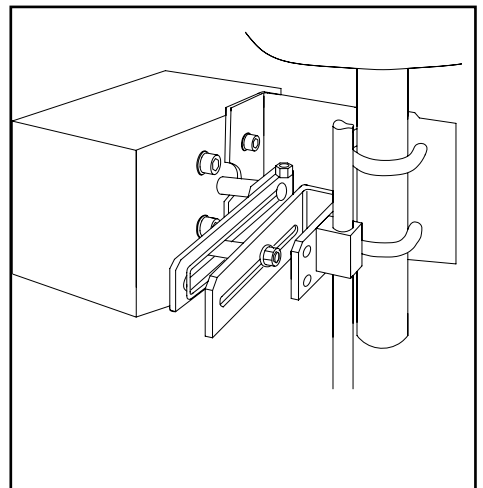

Mounting on a Rod Actuator (IEC 534 part 6)

### ***Follower pin adjustment***

The positioner follower pin must be adjusted to match the valve stroke in the following manner:

1. Adjust the follower pin (STROKE + 10 mm) as indicated on the follower arm's embossed scale.
2. Exhaust the actuator.
3. Loosen the follower pin and shift it along the follower arm until the control marking on the feedback gear is horizontal (points to the center of the feedback potentiometer). Fasten the follower pin in this position.
4. Adjust the actuator to full stroke and check the follower pin adjustment the same way as described in step 3. As the actuator strokes, the rotation of the feedback gear should be between the inner control markings. If the length of rotation is outside the control markings, adjust the follower pin farther out on the feedback lever to reduce the angle of rotation.

**NOTE:** Stroke the actuator carefully and ensure the follower arm does not interfere with valve parts, actuator or positioner. Do not adjust the follower pin too near to the slot end of the take-off arm.

The minimum lateral distance should be approximately 5 mm (0,2 inches) to prevent bending of the feed-back mechanism.

### ***Rotary actuators***

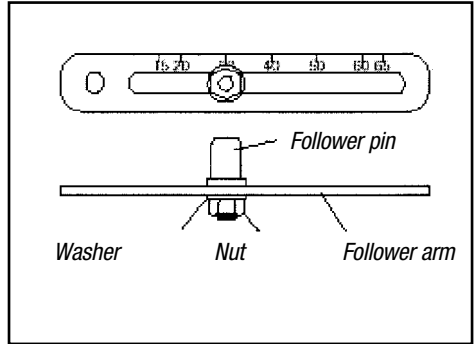

*Follower Arm (standard)*

**Flowact direct mounting**

The positioner follower pin must be adjusted to match the valve stroke in the following manner:

1. Adjust the follower pin (STROKE + 10 mm) as indicated on the follower arm's embossed scale.

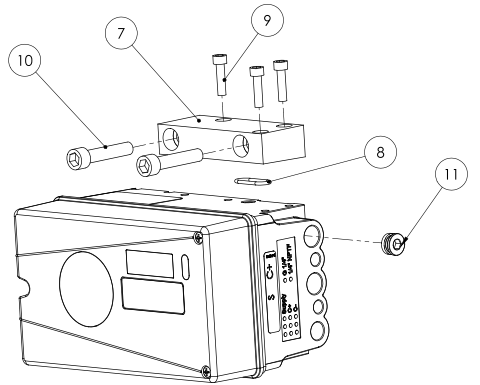
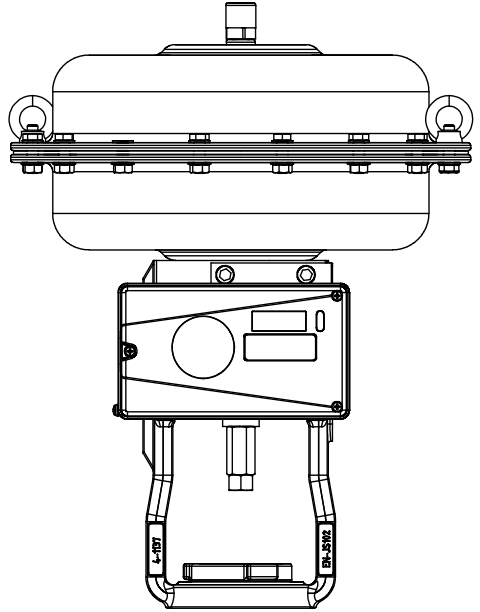

**Pin plate and pin configuration for different actuators and stroke**

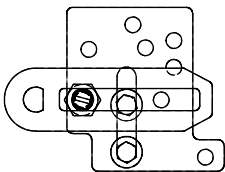

10 mm stroke 252

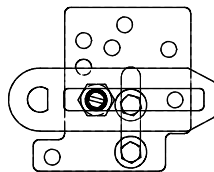

20 mm stroke 252

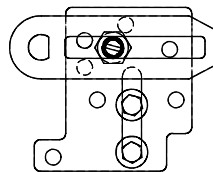

20 mm stroke 502

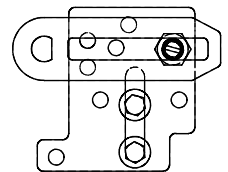

40 mm stroke 502



**Mounting the PMV D20 positioner on a quarter-turn actuator (closed or open by spring)**

The mounting of a pneumatic double-piston part-turn valve actuator (in accordance with VDI/VDE 3845) is described as an example by using the following equipment:

**Quarter-turn valve actuator:** Rack & pinion or scotch yoke, closed or open by spring.

**Rotary actuaors VDI/VDE 3485 (Namur)**

Mount bracket 1 to positioner. Secure with 4 x M6 screws 2. 2.5 nm (1.8 ft lbs )

Fit positioner on actuator and secure with 4 x screws 3.

Install tubing 4 between actuator and positioner.

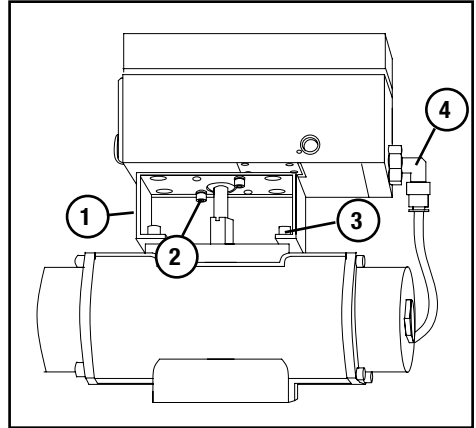

*Gauge block*

Gauge blocks are available for D20 series with 1/4" NPT air connections. To install, ensure seals are aligned, then use 3 Nm (2.2 lb ft) of torque when fastening the gauge block to the positioner using the two screws supplied with the kit.

Gauge blocks are available for D20 series with 1/8" NPT



*Air Connection*

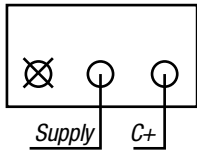

*Single acting positioner, Direct function*

*Actuator with closing spring*

When the control signal increases, the pressure C+ to the actuator is *increased*. The valve stem moves upward and rotates the positioner spindle *counter-clockwise*. When the control signal drops to zero, C+ is vented and the valve closes.

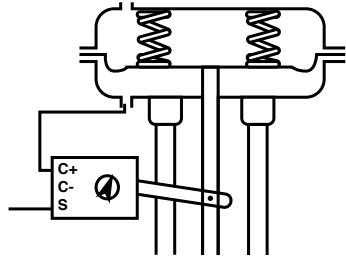

*Reverse function*

*Actuator with opening spring*

When the control signal increases the pressure C+ to the actuator is *increased*. The valve stem moves downward and the positioner spindle rotates *clockwise*. When the control signal drops to zero, C+ is vented and the valve opens.

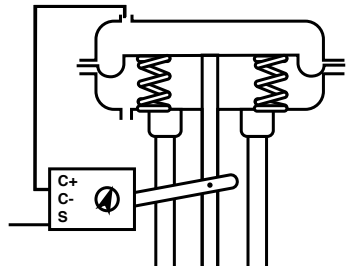

**Electrical connections**

Terminal block diagram for the D20-series. The terminal block (right) for the positioner is accessible when the aluminium cover is removed. The D20-series digital positioner has been designed to operate correctly in electromagnetic (EM) fields found in typical industrial environments. Care should be taken to prevent the positioner from being used in environments with excessively high EM field strengths (greater than 10 V/m). Portable EM

devices such as hand-held two-way radios should not be used within 30 cm of the device. Ensure proper wiring and shielding techniques of the control lines, and route control lines away from electro-magnetic sources that may cause unwanted noise. An electromagnetic line filter can be used to further eliminate noise. In the event of a operability. It may be necessary to recalibrate the D20-series positioner to restore operation.

Use a coin to remove the black plug

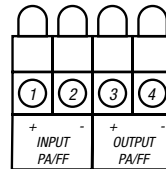
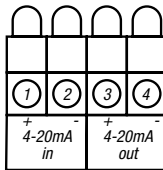
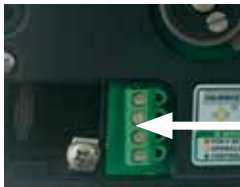

*HART and non HART unit*

1. Input signal + 4-20mA DC
2. Input signal - 4-20mA DC
3. 4-20mA + Feedback 13-28 VDC
4. 4-20mA - Feedback 13-28 VDC

*Profibus and Fieldbus unit*

1. Profibus/Fieldbus +
2. Profibus/Fieldbus -
3. Profibus/Fieldbus +
4. Profibus/Fieldbus -



*D20(D20) optional Switch or remote board*

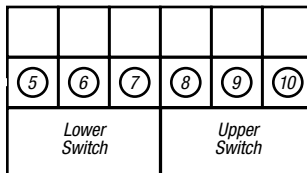

**Warning!** In a hazardous environment where there is a risk of explosion, electrical connections must comply with the relevant regulations.

<i>Switch option</i>		<i>Optional board</i>					
		<i>5</i>	<i>6</i>	<i>7</i>	<i>8</i>	<i>9</i>	<i>10</i>
X	No feedback option	na.	na.	na.	na.	na.	na.
T	4-20 mA transmitter, no switches	na.	na.	na.	na.	na.	na.
5	Slot type Namur sensor, P+F SJ2-SN	-	+	na.	-	+	na.
6	Slot type Namur Sensor, P+F SJ2-N	-	+	na.	-	+	na.
N	Namur V3 type sensor, P+F NJ2-V3-N	-	+	na.	-	+	na.
P	Limit switches Proximity SPDT	NO	NC	Com	NO	NC	Com
S	Limit switches Mechanical SPDT	NC	NO	Com	NC	NO	Com

**Mounting options**

RM	Remote Board (Feedback and switch option =x or T)	na.	na.	na.	CCW	RA	CW
----	---	-----	-----	-----	-----	----	----

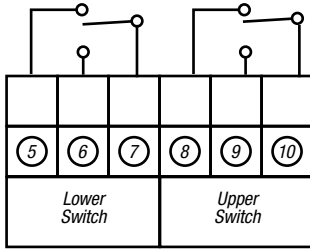

Connection of mechanical and proximity switches. (S,P)

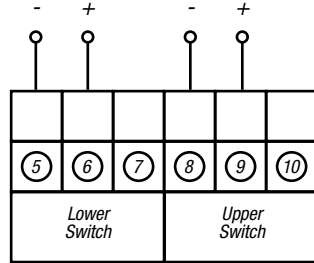

Connection of Namur switch. (N,5,6)

*Limit switch calibration*

- **Losen screws (1) and adjust cams.**
- **Adjust lower cam first and then upper cam**
- **Tighten screws (1)**

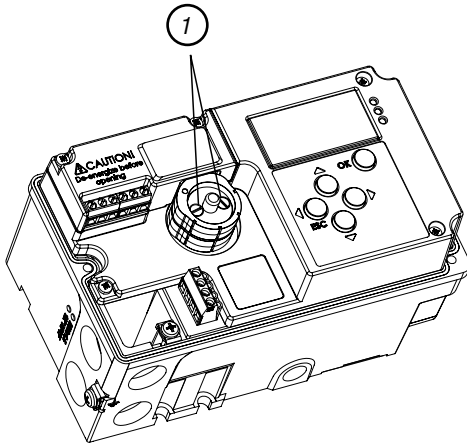



## 8. Control

### ***D20 Single Button***

#### ***Calibration***

- A. Apply 4 mA current as input signal.
- B. Wait for the Yellow LED to flash and then press the button for 5 sec. (Release the button when the three LEDs start to flash alternately).
- C. The calibration process starts and will take between 30 seconds to some minutes depending on the actuator size. The actuator goes to maximum, minimum positions and calculates the control parameters. The three LEDs will flash alternately during the calibration process.
- D. When calibration is completed, the 3 LEDs will rapidly flash alternately for a moment.

A successful calibration is indicated by yellow or green LED:

- G**  Green LED flashes = In service
- Y**  Yellow LED flashes = In service. The unit vents in max or min position.

An unsuccessfull calibration is indicated by error codes:

- R**  D20 does not reach the setpoint.



**Set of Direct or Reverse action**

**Note! For safety reason, this operation has to be done max 5 minutes after calibration. If time has run out, or if power is disconnected during the five minutes, perform a new cali-bration, before changing the direction.**

Run 4 mA. If valve is in right position, then check the position over the whole range (8, 12, 16 and 20 mA).



x3

If the direction need to be changed: press the button 3 times and the direction will change.

Check operation at 4 – 8 – 12 – 16 and 20 mA

**Show gain setting**

If the actuator position is unstable or selfoscillating after calibration, the gain can be adjusted.

Gain can be set from A (lowest) to G (highest). Default is D.



x4

To show the current gain setting, press the button four times.

To indicate the current setting, the LEDs flashes according to the following:

LEDs show:		G (Highest)
LEDs show:		F
LEDs show:		E
LEDs show:		D Default
LEDs show:		C
LEDs show:		B
LEDs show:		A (Lowest)

The gain code sequence is repeated 5 times.



**Button functions:**

- Press 5 sec = Calibration
- Press x3 = Direct/reverse action
- Press x4 = Show gain setting
- Press x5 - x11 = Change gain setting

To indicate that a command is accepted, the three LED:s light up.



***Change of gain setting***

To lower the gain, press the button: 7, 6 or 5 times (5= lowest).

To increase the gain (if actuator is moving to slow).

Press the button: 9, 10 or 11 times (11= highest) to increase the gain.

The LED:s flashes alternately when the button is pressed. After gain change the LED:s show the gain code five times.

The default value after first calibration is D .

After this, the gain settings are finished.

●	x11	G (Highest)	↑↑ Higher Lower ↓↓
●	x10	F	
●	x9	E	
●	x8	D Default	
●	x7	C	
●	x6	B	
●	x5	A (Lowest)	

**Factory reset, initial calibration of the 4-20mA input and output signals and D20 calibration**

- A. Press and hold button while switching on power (4-20 mA input) to the D20, keep the button pressed for 6 sec. The EEPROM will now be erased. Release the button when all three LEDs light up for a moment.
- B. Wait for the LEDs to start flashing yellow – red alternately. D20 is now in FACTORY MODE.

**To calibrate 4-20 mA input signal**

- C. Apply 4.0 mA input signal and then press the button three (3) times until the 3 LEDs will rapidly flash alternately for a moment and then LEDs will flash yellow – red again.
- D. Apply 20.0 mA input signal and then press the button three (3) times until the 3 LEDs will rapidly flash alternately for a moment and then the LEDs will flash yellow – green again.

**To calibrate 4-20 mA output signal**

- E. The feedback transmitter output signal on pins 3 and 4 will now follow the input signal instead of the position. Apply 20.0 mA input signal, measure the output signal and adjust the input signal up/ down until the output signal is 20.0 mA. Then press the button three (3) times until the 3 LEDs will rapidly flash alternately for a moment and LEDs will flash yellow – green again.
- F. The output signal on pins 3 and 4 will continue to follow the input signal instead of the position. Apply 4.0 mA input signal, measure the output signal and adjust the input signal up/ down until the output signal is 4.0 mA. Then press the button three (3) times until the 3 LEDs will rapidly flash alternately for a moment and yellow LED will flash.

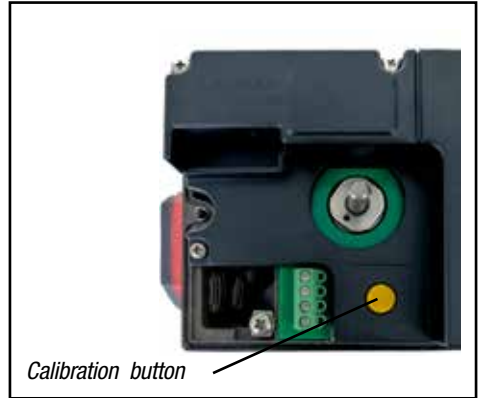

- G. The D20 is now ready for calibration.

Refer to [page 23](#) for the D20 calibration process.

**Note:** The whole processes specified on this page should be completed for the D20 to function properly.

**D22 Menus and 5 Pushbuttons**

The positioner is controlled using the five pushbuttons and the display, which are accessible when the aluminum cover is removed.

For normal functioning, the display shows the current value. Press the ESC button for two seconds to display the main menu.

Use the pushbuttons  to browse through the main menu and the sub-menus.

The main menu is divided up into a basic menu and a full menu.

*Other functions*

*ESC*

Exit the menu without making any changes (as long as any changes have not been confirmed with OK).

*FUNC*

To select function and change parameters.

*OK*

To confirm selection or change of parameters.

*MENU INDICATOR*

Displays the position of the current menu row in the menu.

*IN SERVICE*

The positioner is following the input signal. This is the normal status when the positioner is working.

*OUT OF SERVICE*

The positioner is not following the input signal. Critical parameters can be changed.

*MANUAL*

The positioner can be stroked manually using the pushbuttons. See section “Man/Auto”, [page 37](#).

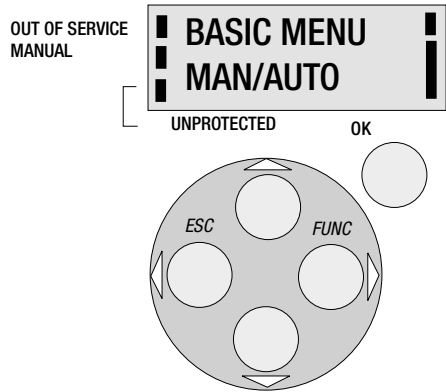

*UNPROTECTED*

Most of the parameters can be changed when the positioner is in the “Unprotected” position. However, critical parameters are locked when the positioner is in the “In service” position.

LED color (R=Red, Y=Yellow, G=Green)

Codes during In Service		
	R	Actual valve position deviates from requested/set position
	Y	Fully opened/closed valve using Cut Off (= OK)
	G	Controlling valve position (= OK)

Codes during Out of service			
	R	Y	Input signal not calibrated
	Y	G	Feedback signal not calibrated
	Y	Y	Out of Service (= OK)

Calibration alarm				
	R	G	No feedback movement. Check linkage from actuator to positioner	
	R	Y	No air available. *(alarm available only when pressure sensors installed)	
	R	G	G	No pot connection. Check pot cable inside positioner.
	R	Y	Y	No air relay. Check cable inside positioner.
	R	Y	G	Pot not calibrated. Go to Calibrate->Expert->Pot on LCD menu.

**Menu indicator**

There are indicators at both sides of the display window and they indicate as follows:

Flashing in position *Out of service*

Flashing in position *Manual*

Displayed in position *Unprotected*

The indicators on the right-hand side show the position in the current menu.

**Menus**

To display the menus you can select:

- *Basic menu*, which means you can browse through four different menu items

- *Full menu*, which comprises ten steps. Use the Shift Menu to browse through the menu items

Full Menu can be locked out using a passcode.

The main menus are shown on the next page and the sub-menus on the subsequent pages.

**Changing parameter values**

Change by pressing   until the desired figure is flashing.

Press  to step to the desired figure. Confirm by pressing OK.

A change can be undone by pressing the *ESC* button, which returns you to the previous menu.

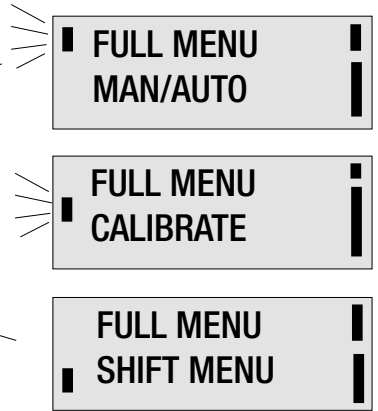

**Basic Menu**

Menu system

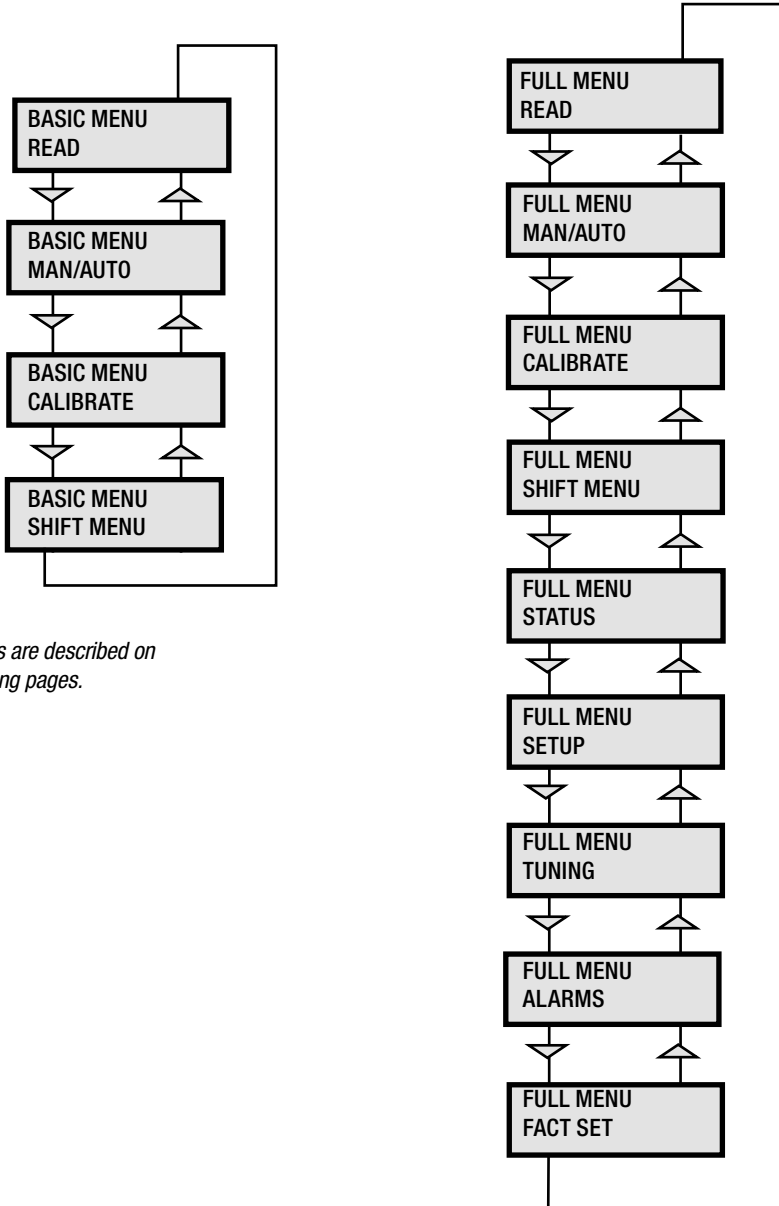

The menus are described on the following pages.



*First start*

“Calibrate” is displayed in the basic menu automatically, the first time power is applied. It can be selected from the basic or full menu at any time.

*Tip! Instant quick calibration*

The D22 can be instantly calibrated by pressing the top + bottom buttons for 5 seconds (see picture). This function is available from any menu position.



A complete auto-calibration will take a few minutes depending on size of actuator and includes end limit calibration (zero and span), auto-tuning (dynamically sets the control parameters for the actuated package the positioner is controlling) and a check of the movement speed. Start the automatic calibration by selecting *Auto-Cal* and then answer the questions in the display by pressing *OK* or the respective arrow.

*Calibration error messages*

If a fault occurs during calibration, one of the following error messages can be displayed:

*No movement/press ESC to abort*

Typically the result of an air delivery issue to the actuator, a stuck valve or actuator, or incorrect mounting and/or linkage arrangement. Check for proper supply air to the positioner, pinched tubing, proper actuator sizing, proper linkage and mounting arrangement.

*Pot uncalibrated/press ESC to abort*

The potentiometer is out of range. The potentiometer is aligned using the Calibrate - Expert cal - pot Menu. The calibration sequence must be restarted after the fault is corrected.

*Instant quick calibration*

*First start, Profibus PA*

For Profibus PA, connect the input signal at pos 1 and 2 on the terminal block. See Electrical connections in the manual.

In the SETUP/Devicedata/Profibus: change the address from 126 to any number between 1-125. Never use the same number with more than one unit. Install values in failsafe mode, for communication when loss of signal.

Calibrate the unit.

GSD files are available at our web-page [www.pmv.nu](http://www.pmv.nu)

*To install the D20\_PROFIBUS.DDL file to Siemens SIMATIC PDM.*

1. Move the files to the directory where the DeviceInstall.exe is located.
2. Run DeviceInstall.exe

<i>Parameter</i>	<i>Description</i>		<i>BYTE</i>
SP	Setpoint	The SP has 5 bytes, 4 bytes for the float value and one status byte. The status byte needs to be 128 (0x80Hex) or higher for the D20 to accept it.	4+1=5
READBACK	Position	The READBACK has 5 bytes, 4 bytes for the float value and one status byte.	4+1=5
POS_D	Digital position	Returns actual position as a digital value with definitions as below 0 = Not initialized 1 = Closed 2 = Opened 3 = Intermediate	2
CHECKBACK		Detailed information of the device, coded bit wise. Several messages can occur at the same time.	3
RCAS_IN	Remote Cascade	The RCAS_IN has 5 bytes, 4 bytes for the float value and one status byte.	4+1=5
RCAS_OUT	Remote Cascade	The RCAS_OUT has 5 bytes, 4 bytes for the float value and one status byte.	4+1=5

*Status Byte Table*

<i>MSB</i>					<i>LSB</i>	<i>Meaning</i>	<i>D20 info</i>		
0	0	0	0	1	0	x	x	Not connected	
0	0	0	0	1	1	x	x	Device failure	PROFibus PA module failure
0	0	0	1	0	0	x	x	Sensor failure	No sensor value
0	0	0	1	1	1	x	x	Out of service	AI Function Block in O/S mode
1	0	0	0	0	0	x	x	Good - Non cascade	Measured value OK All Alarm values used
1	0	0	0	0	0	0	0	OK	
1	0	0	0	1	0	0	1	Below low limit Lo	Advisory alarm
1	0	0	0	1	0	1	1	Above high limit Hi	Advisory alarm
1	0	0	0	1	1	0	1	Lo-Lo	Critical alarm
1	0	0	0	1	1	1	1	Hi-Hi	Critical alarm

Example SP = 43.7% and 50%

<i>Float</i>	<i>Hex</i>	<i>Status</i>
43.7	42 2E CC CD	80
50.0	42 48 00 00	80

*(FF) Foundation Fieldbus function blocks*

Function blocks are sets of data sorted by function and use. They can be connected to each other to solve a control process, or to a controlling DCS. To get a good introduction and understanding of FF look at [www.fieldbus.org](http://www.fieldbus.org) and download the “Technical Overview” from the About FF pages.

*(TB) Transducer Block*

The TB contains unit specific data. Most of the parameters are the same as parameters found on the display. The data and the order of data varies between different products. The AO-block setpoint (SP) and process value (PV) parameters are transceived to the TB through a channel. The TB has to be in AUTO for the AO-block to be in AUTO.

The positioner has to be in menu-auto mode and in service to be controlled from the fieldbus. If the positioner is placed in menu-manual mode then the transducer block will be forced to (LO) local override. In this way a person in the field will be able to control the positioner from the keypad, without collision with a control loop.

*(RB) Resource Block*

The RB is a set of parameters that looks the same for all units and products. The values of the RB define unit information that concerns the Fieldbus Protocol such as MANUFAC\_ID which informs the unique manufacturer id. For Flowserve it is 0x464C53. The RB has to be in AUTO for the AO-block to be in AUTO.

*(AO) Analogue Output Block*

The AO follows Fieldbus Foundation’s standard on content and action. It is used for transferring (SP) setpoints from the bus to the positioner.

CAS\_IN (cascade input) and RCAS\_IN (remote cascade input) are selected as inputs to the AO block depending on the MODE\_BLK parameter. The selected input will be relayed to the SP parameter of the AO block. BKCAL\_OUT (back calculated output) is a calculated output that

AO-block overview

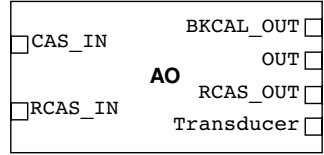

can be sent back to a controlling object so that control bumps can be avoided. Usually the BKCAL\_OUT is set to be the (PV) process value of the AO-block, i.e. the actual measured position of the valve. OUT is the primary calculated output of the AO block. During a limited action (ramping) of the AO block the RCAS\_OUT parameter will supply the final setpoint and the OUT parameter will be the limited output. The transducer block is connected through a channel to the AO block. Through this channel the OUT value and SP are transceived.

In order to set the AO block to AUTO, the TB and the RB have to be in AUTO. Further the AO block has to be scheduled. Using National Instruments Configurator; scheduling can be done by adding the unit to a project and then click on the “upload to device” icon.

To write a setpoint value by hand, add Man to MODE->Permitted parameter, and then choose MODE->Target to Man. Make sure that the unit is scheduled.

*Example*

A typical FF block loop control might look like the following: Where the positioner is represented by the AO-block.

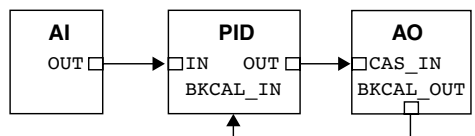





The contents of the menu are shown on the next page. The various menu texts are described below.

*Auto-Cal*

Auto-tuning and calibration of end positions

*Start tune*

Starts the tuning. Questions/commands are displayed during calibration. Select the type of movement, function, etc. with  and confirm with OK as shown in the chart on the next page.

*Lose prev value? OK?*

A warning that the value set previously will be lost (not during the first auto-tuning).

*Direction? Air-to-open.*

Select for direct function.

*Direction? Air-to-close.*

Select for reverse function.

*In service? Press OK*

Calibration finished. Press OK to start positioner functioning. (If ESC is pressed, the positioner assumes the "Out of service" position but the calibration is retained).

*TravelCal*

Calibration of end positions

*Start cal*

Start end position calibration.

*Lose prev value? OK?*

A warning that the previously set value will be lost. Confirm with OK. The calibration sequence starts.

*In service? Press OK*

Calibration finished. Press OK to start positioner functioning. (If ESC is pressed, the positioner assumes the "Out of service" position but the calibration is retained).

*Perform*

Setting gain

*Normal*

100% gain

*Perform G, F, E, D, C, B, A*

Possibility to select a lower gain in steps. Default setting is D.

*Note.* Original P. I. D. will always be shown in display

**Feedback option (cont.)**  
**Calibration of the 4-20 mA transmitter**

Go to menu shown in diagram.  
 Connect mA meter I and check reading.  
 Adjust output signal using Up or Down key  
 until meter I reads 4.00 mA.  
 Finish by pressing OK.  
 Repeat the above for 20 mA.

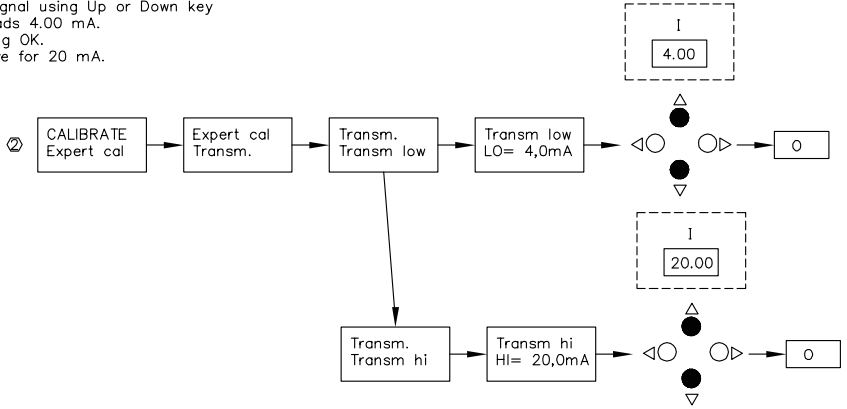

*Expert Calibration*

When entering “ExpertCal” mode - walk through the list of parameters described below. Set values where applicable. Confirm by pressing OK.

*Set point LO:* Use the calibrator set to 4 mA (or set another value on the display). Press OK.

*Set point HI:* Use a calibrator of 20 mA (or set another value on the display). Press OK.

*Pressure LO:* Use a supply of 1.4 bar (20 psi) (or set another value on the display). Press OK. Pressure read out only possible on D20 with built in pressure sensor.

*Pressure HI:* Use a supply of 8 bar (115 psi) (or set another value on the display). Press OK. Pressure read out only possible on D20 with built in pressure sensor.

*Transmitter:* Connect 10 - 28 VDC. Connect an external mA meter to the loop. Read low value on mA meter and adjust with up/down key. Press OK to set low value. Repeat procedure to set High value. Also see video on [www.pmv.nu](http://www.pmv.nu)

*Pot:* Potentiometer setting, see section 5. Also see video on [www.pmv.nu](http://www.pmv.nu)

*Full reset:* Resets all set values and enters Factory mode. To reset the values only, use FACT SET in main menu, see below.

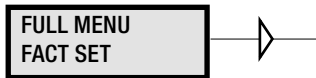

The menu contents are shown in the chart below.

The default values that were set on delivery can be reset using the Fact Set menu. Values from calibration and from other settings will then be lost.

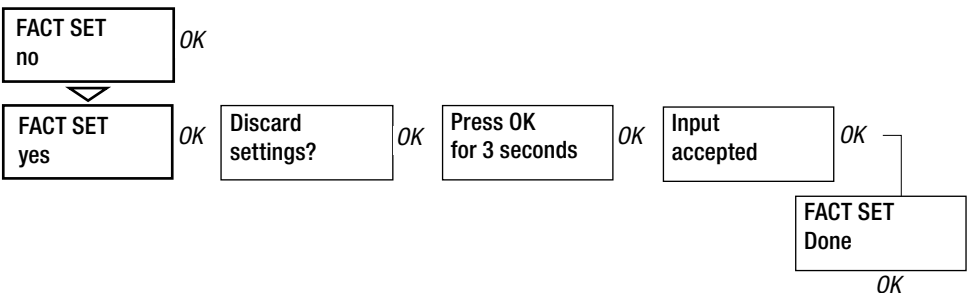

The menu contents are shown in the figures on the right and the texts are described below:



Current values can be read using the Read Menu and some values can be reset.

- Pos* Shows current position
- Set&pos* Set point and position
- Set&dev* Set point and deviation
- Pos graph* Shows position graph
- Temp* Shows current temperature
  
- Statistics**
- n cycles* Shows number of cycles.  
1 cycle = [move of valve +change direction+move opposite direction] regardless of size of each move/stroke.
- Acc travel* Travel = [accumulated % valve has moved/100].  
  
Example: move 60% up + move 40% down =>Acc travel = 1
- mean dev* Shows accumulated deviation in %
- m.abs dev* Shows accumulated absolute deviation in %
- # of resets* Shows number of resets
- runtime* Shows accumulated runtime since last reset
- Extr temp* Shows extreme min and max temperature
- Histogram* Shows position and time for position value
- Alarms* Displays tripped alarms

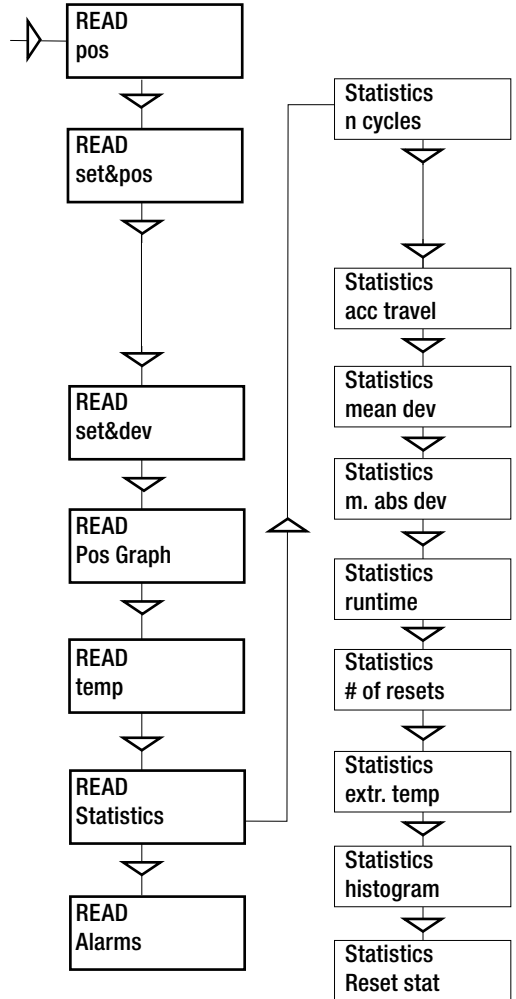



*The Man/Auto menu is used to change between manual and automatic modes.*

The menu contents are shown in the figures on the right and the various texts are described below:

*AUT, OK = MAN*

Positioner in automatic mode

*MAN, OK = AUT*

Positioner in manual mode

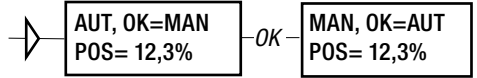

When changing between *MAN* and *AUT* mode, the *OK* button must be pressed for 3 seconds.

In the *MAN* mode, the value of POS can be changed using  $\blacktriangle$   $\blacktriangledown$ . The push-buttons increase/decrease the value in steps. The value can also be changed in the same way as for the other parameter values, as described on [page 28](#)

*Other functions*

C+ can be fully opened by pressing  $\blacktriangle$  and then immediately *OK* simultaneously.

C- can be fully opened by pressing  $\blacktriangledown$  and *OK* simultaneously.

C+ and C- can be fully opened for blowing clean by pressing  $\blacktriangle$  $\blacktriangledown$  and *OK* simultaneously.



The Shift Menu is used to choose between the basic menu and the full menu.

The menu contents are shown in the figures on the right and the various texts are described below:

- No            Full menu selected.
- Yes           Basic menu selected.

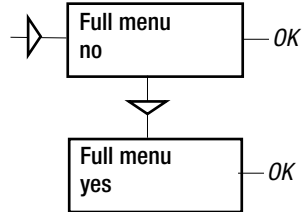

The Menu can be locked with a passcode, see Setup menu.

**Full Menu**

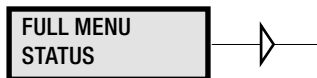

The Status Menu is used to select whether or not the positioner is in service.

The menu contents are shown in the figures on the right and the various texts are described below:

- o o service    Not in service. Flashing indicator in upper left-hand corner of display.
- in service    Positioner in service. Critical parameters cannot be changed.

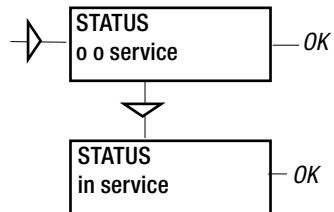

When changing between In service and Out of service, the OK button must be pressed for 3 seconds.



The Setup Menu is used for various settings.

The menu contents are shown in the chart on the next page and the various texts are described below:

<i>Actuator</i>	<i>Type of actuator</i>	<i>Size of actuator</i>	<i>Time out</i>
Rotating	Rotating actuator.	Small	10 s
Linear	Linear actuator.	Medium	25 s
		Large	60 s
		Extra large	180 s
<i>Lever</i>	<i>Only for linear actuator.</i>		
Lever stroke	Stroke length to achieve correct display. Input only needed in case display value is off		
Level cal	Calibration of positions to achieve correct display.		
<i>Direction</i>			
Direct	Direct function (signal increase opens). Indicator/spindle rotates counter-clock wise.		
Reverse	Reverse function.		
<i>Character</i>	<i>Curves that show position as a function of input signal.</i>		
Linear	} See diagram.		
Equal %			
Quick open			
Sqr root			
Custom			
<i>Cust chr</i>			
# of point	Specify number of points (3, 5, 9, 17, or 33)		
Cust curve	Enter values on X and Y axes.		
<i>Curr range (Use this function to split range)</i>			
0%=4.0 mA	Possibility of selecting which input signal values will correspond to 0% and 100% movement respectively.		
100%=20.0 mA			
Examples of settings:	4 mA = 0%, 12 mA = 100%, 12 mA = 0%, 20 mA = 100%.		

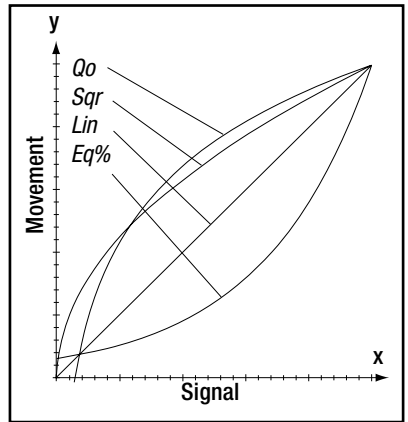

<p><i>TRVL range</i> 0%=0.0%</p>	<p><i>Setting end positions</i> Select Out of Service. Set percentage value for desired end position (e.g. 3%).</p>	<p>Start menu</p>	<p>Start in Basic menu or Full menu.</p>
<p>Set 0%</p>	<p>Select In Service. Connect calibrator. Move forward to desired end position (0%) and press OK.</p>	<p>Orient</p>	<p>Orientation of text on display.</p>
<p>100%=100.0%</p>	<p>Select Out of Service. Set percentage value for desired end position (e.g. 97%).</p>	<p>Par mode</p>	<p>Display of control parameters such as P, I, D or K, Ti, Td.</p>
<p>Set 100%</p>	<p>Select In Service. Connect calibrator. Move forward to desired end position (100%) and press OK.</p>	<p><i>Devicedata</i> HW rew SW rew Capability HART</p>	<p>} General parameters.</p> <p>Menu with HART parameters. Only amendable with HART communicator. It is possible to read from display.</p>
<p><i>Trvl ctrl</i> Set low</p>	<p><i>Behavior at set end position</i> Choose between Free (positioner will control until a mechanical top is reached), Limit (stop at set end position), and Cut off (Default value. Go directly to a mechanical stop at a redefined setpoint).</p>	<p>Profibus PA</p>	<p>Status Indicates present status</p>
<p>Set high Values</p>	<p>Similar to Set low. Select position for Cut off and Limit at the respective end positions.</p>	<p>Status Device ID Address Tag Descriptor Date Failsafe</p>	<p>Serial number 1-126 Allotted ID ID description SW release date Value = preset pos Time = Set time +10sec= time before movement Valve act = failsafe (preset pos) or last value (present pos) Alarm out= On/Off</p>
<p><i>Passcode</i></p>	<p><i>Setting passcode for access to the menu</i></p>	<p>Device ID Nod address TAG-PD_TAG</p>	<p>Foundation Fieldbus Serial number Address on the bus provided by the DCS system Name provided by the DCS system</p>
<p>Numbers between 0000 and 9999 can be used as passcodes. 0 = no passcode required.</p>	<p></p>	<p>Descriptor Date Sim jumper</p>	<p>D20 positioner SW release date Simulate jumper, FF simulation functionality activated = ON</p>
<p><i>Appearance</i> Language Units Def. Display</p>	<p><i>On display</i> Select menu language. Select units. Select value(s) to be displayed during service. The display reverts to this value 10 minutes after any change is made.</p>	<p></p>	<p></p>





The menu contents are shown in the chart on the next page and the various texts are described below:

*Close time*      Minimum time from fully open to closed.

*Open time*      Minimum time from closed to fully open.

*Deadband*      Setting deadband. Min. 0.1%.

*Expert*      Advanced settings.

*Control*      See explanations below.

*Togglestep*      Test tool for checking functions. Overlays a square wave on the set value.

*Self test*      Internal test of processor

*Undo*      You can read last 20 changes.

*P,I,D and K,Ti,Td parameters*

---

If one of the gains is changed, the corresponding value in the other gain set is changed accordingly.

**FULL MENU  
ALARMS** 

The menu contents are shown in the chart on the next page and the various texts are described below:

- |                   |  |                      |
|-------------------|--|----------------------|
| <i>Deviation</i>  | <i>Alarm generated when deviation occurs</i>           |                      |
| <i>On/Off</i>     | <i>Alarm on/off.</i>                                   |                      |
| <i>Distance</i>   | <i>Allowed distance before alarm is generated.</i>     |                      |
| <i>Time</i>       | <i>Total deviation time before alarm is generated.</i> |                      |
| <i>Alarm out</i>  | <i>Select ON/OFF offers output on terminals.</i>       |                      |
| <i>Valve act</i>  | <i>Behavior of valve when alarm is generated.</i>      |                      |
|                   |  |                      |
| <i>Limit 1</i>    | <i>Alarm above/below a certain level.</i>              |                      |
| <i>On/Off</i>     | <i>Alarm on/off.</i>                                   |                      |
| <i>Minipos</i>    | <i>Setting of desired min. position.</i>               | } See diagram below! |
| <i>Maxpos</i>     | <i>Setting of desired max. position.</i>               |                      |
| <i>Hysteresis</i> | <i>Desired hysteresis.</i>                             |                      |
| <i>Alarm on</i>   | <i>Select ON/OFF offers output on terminals.</i>       |                      |
| <i>Valve act</i>  | <i>Behavior of valve when alarm is generated.</i>      |                      |
| <i>Limit 2</i>    | <i>See Limit 1.</i>                                    |                      |

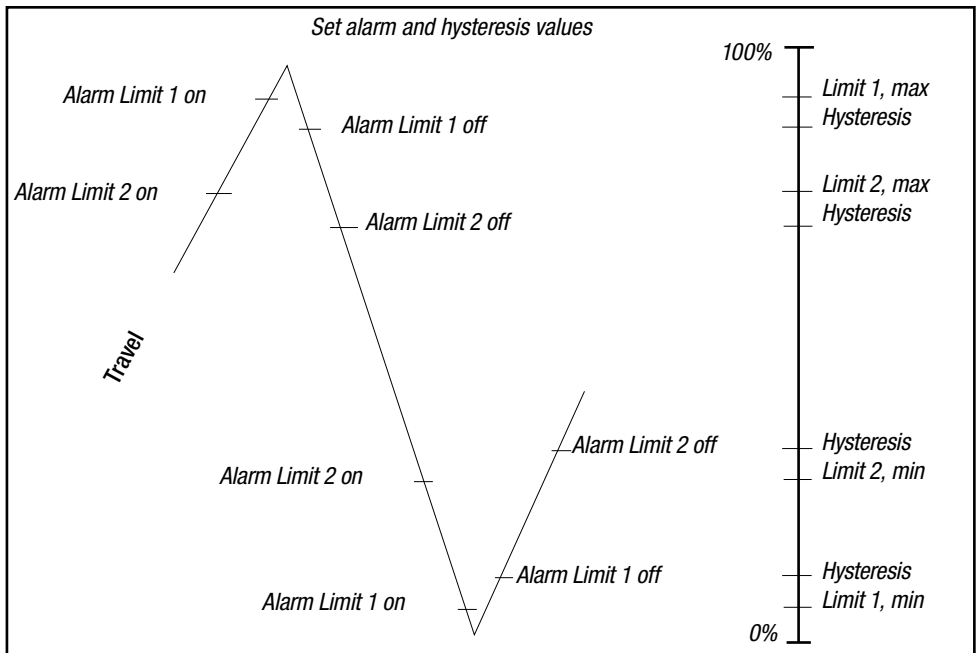

<i>Temp</i>	<i>Alarm based on temperature</i>
On/Off	Temperature alarm on/off.
Low temp	Temperature setting.
High temp	Temperature setting.
Hysteresis	Allowed hysteresis.
Alarm out	Select ON/OFF offers output on terminals.
Valve act	Behavior of valve when alarm is generated.

<i>Valve act</i>	
No action	Alarm generated only. Operations not affected.
Goto open	Valve moves to 100%. Positioner changes to position Manual.
Goto close	Valve moves to 0%. Positioner changes to position Manual.
Manual	Valve stays in unchanged position. Positioner moves to position Manual.

Replacement for page xx in the D30 IOM for software version 1.2

<b>READ</b>							pos	
<b>MAN/AUTO</b>	AUT_OK=MAN	MAN_OK=AUT					set&pos	
<b>CALIBRATE</b>	AutoCal			G Highest		set&dev		
	TravelCal			F		Pos Graph		
	Balance			E		Supply Pr**	n cycles	
	Perform			D default		C+ & C-**	acc travel	
	Expert cal		pot	C		temp	mean dev	
			full reset	B		outsignal	m. abs dev	
				A Lowest		statistics	runtime	
				normal		alarms	# of reset	
							extr temp	
							Histogram	
							Reset stat	
<b>SHIFT MENU</b>	Basic menu							
	Full menu							
		Type	rotating	single act	small			
		Function	linear	double act	medium			
<b>STATUS</b>	O O SERVICE	Size			large			
	IN SERVICE				Texas-size			
<b>SETUP</b>	Actuator					linear		
	Lever*		Stroke	Air To Open		equal %		
			Lever cal	Air To Close		quick open		
	Direction					custom		
	Character					sqr root		
	Cust chr						#of points X0=	
							Cust curve Y0=	
			0% =					
			Set 0%					
	Curr range		100%=	0% =				
			Set 100%	Set 0%				
	Trvl range			100%=				
				Set 100%				
	Trvl ctrl	Set low	free		Cutoff Low	Direction	direct	
		Set high	cutoff		Cutoff HI	Limit Low	reverse	
		Values	limited		Limit Low	Limit Hi	Position	
	Transm.				Limit Hi	Pos/Set	Set Point	
	Passcode	Old	New 0=Off					
	Appearance	Language	english					
			svenska					
			deutsch					
			français	percent				
			italiano	mA				
			español	mm	percent			
			norsk	cm	mm			
			chinese	inch	cm			
		Units	degrees	degrees	inch	bar		
		Setpoint			degrees	psi	Grad C	
		Position				kPa	Grad F	
		Pressure**					Kelvin	
		Temp						
	Def. Displ							
	Start menu							
	Start Logo	On/off	last value		position	set&pos		
	LED	On/off	basic		set&dev	menu	Message	
	Orient.	normal	full				Tag	
		flipped					Descriptor	
	Devicedata						Date	
							Device ID	
							Poll adr	
							Assemblyno	
							Univ cmd	
							Spec cm	
							Burst	
							On/off	
<b>TUNING</b>	Close time	Control	(x)					
	Open time	Toggle/step			PID params			
	Deadband	Self test			K,Ti,Td			
	Expert	Leakage			Spring Adj			
		Undo			Friction			
							Run time	
							cycle time	
							size	
							start	
							Abort step	
<b>ALARMS</b>	Deviation					On/off		
	Limit	On/off				Distance		
		Minpos				Time		
		Maxpos				Alarm out		
		Hysteresis				Valve act		
		Alarm out						
		Valve act	On/off	On/off				
			Max diff	Min Pres				
			Valve act	Valve act				
	Pos=Pres				On/off			
	Pressure				Low temp		no action	
					High temp		goto open	
					Hysteresis		goto close	
					Alarm out		manual	
					Valve act			
	Temp				Valve act			
<b>FACT SET</b>	no							
	yes							

(\*) appear if Linear set  
 (\*\*) appear if pressure sensor exist  
 (x) Position is show in upper row (PID, KITtd, Min Pulse)

## 9. Maintenance/service

When carrying out service, replacing a circuit board, etc., it may be necessary to remove and refit various parts of the positioner. This is described on the following pages.

Read the Safety Instructions on [page 4](#) and [page 5](#) before starting work on the positioner.

Cleanliness is essential when working with the positioner. Contamination in the air ducts will inevitably lead to operational disturbances. Do not disassemble the unit more than that described here.

DO NOT disassemble the valve block apart because its function will be impaired.

When working with the D20 positioner, the work place must be equipped with ESD protection before the work is started.



Always turn off the air and electrical supplies before starting any work.



Please see section for special conditions for safe use and spare parts on [page 5](#)!

Please contact a Flowserve office for information regarding proper procedures.  
[www.pmv.nu](http://www.pmv.nu) or [infopmv@flowserve.com](mailto:infopmv@flowserve.com)

### Disassembling D20

#### Removing cover and inner cover

- Unscrew the screws A and remove the cover. When mounting cover – see [page 5](#). Torque the screws to 0,9 Nm.
- Pull off the arrow pointer, B.
- Unscrew the screws C and remove the inner cover. In reinstalling the inner cover, torque the screws to 0,4 Nm.
- If equipped with switches remove the cam stack

**Note:** Removing inner cover will void warranty.

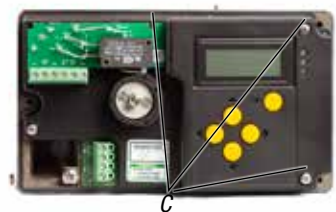
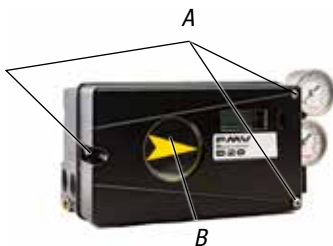

*Circuit boards (PCB)*



*Disconnect or switch off the electric power supply before starting any work.*

- Lift off the display PCB..
- Release the cable connections.
- Unscrew the two screws B and lift up the circuit board.
- In reinstalling the circuit board, torque the screws to 0,4 Nm.

*B*



*Limit Switches*

Loosen two x screws holding the plastic cover and remove the screws. Pull out the plastic cover. Break away the plastic protection located on the main plastic cover to ensure there is an opening for the switches/cams. In reinstalling the plastic cover, torque the screws to 0,4 Nm.

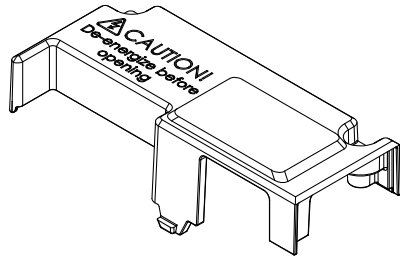

When installing the switch card, make sure it is placed correctly. Secure the PC Board with the two screws holding the plastic cover. Make sure the holes are centred before tightening the screws. Torque the screws to 0,4 Nm.

*Note!* When installing the cam assembly for mechanical switches, retract both switch arms first.

Install the cam assembly and tighten the screws loosely to obtain enough friction to lock the cams.

Adjust the lower cam first, then the upper cam.



*Valve block*



Turn off the air and electric power supply before starting any work.

- Remove the three screws A and lift out the valve block

*Do not disassemble the valve block*

- When installing the valve block — torque the two screws to 0,4 Nm and seal with Loctite® 222.

*Pressure sensors (option)*

Two pressure sensors are available as an option. They indicate pressure for supply and C+ air, and can be used by ValveSight™ to enable advanced valve diagnostics.

The sensors are mounted on a circuit board which mounts next to the air relay on the floor of the housing at B using three screws. Torque the screws to 0,4 Nm.

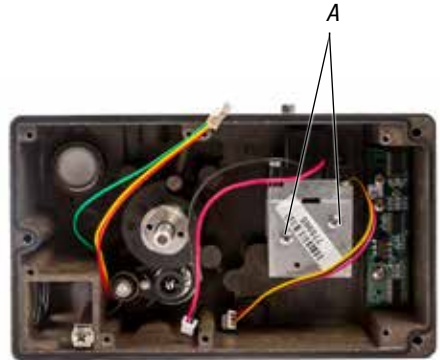

*Pressure sensor PCB - top view*



*Pressure sensor PCB - bottom view*



*Potentiometer*

*90° (270°) spring loaded potentiometer*

The spring-loaded potentiometer can be removed from the gearwheel for calibration or replacement.

If the potentiometer is replaced or the setting is changed, it must be calibrated.

- Select the menu Calibrate - Expert - Cal pot. The display shows Set gear.

- Turn the spindle shaft clockwise to end position and press OK. Either turn manually or use the up/down arrows (with supply air) to stroke the positioner to turn the shaft clockwise.
- Move spring (1) aside and disengage cogwheels. Turn potentiometer according to display until OK is shown. Press OK. See drawing below.
- Move back spring (1) and secure potentiometer (2) calibration. See drawing below. Spring (1) must allow a small play but not so big that the cogs can disengage.

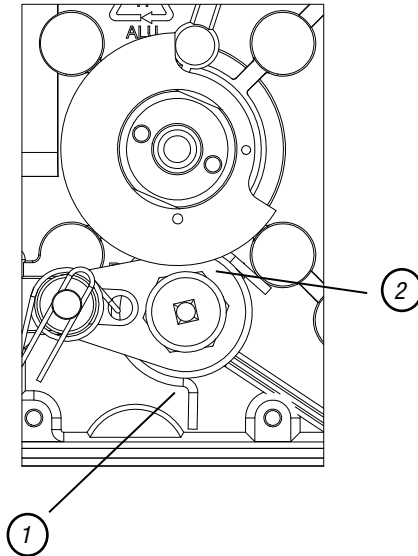

Potentiometer and cogwheel for 90° rotation

## 10. Trouble shooting

<i>Symptom</i>	<i>Action</i>
Input signal change to positioner does not affect actuator position.	<ul style="list-style-type: none"> <li>• Check air supply pressure, air cleanliness, and connection between positioner and actuator.</li> <li>• Out of service, in manual mode.</li> <li>• Check input signal to positioner.</li> <li>• Check mounting and connections of positioner and actuator.</li> </ul>
Change in input signal to positioner makes actuator move to its end position.	<ul style="list-style-type: none"> <li>• Check input signal.</li> <li>• Check mounting and connections of positioner and actuator.</li> </ul>
Inaccurate control.	<ul style="list-style-type: none"> <li>• Perform Auto-calibration and check for any leaks.</li> <li>• Try high and low gain settings.</li> <li>• Uneven air supply pressure.</li> <li>• Uneven input signal.</li> <li>• Wrong size of actuator being used.</li> <li>• High friction in actuator/valve package.</li> <li>• Excess play in actuator/valve package.</li> <li>• Excess play in mounting of positioner on actuator.</li> <li>• Dirty/humid supply air.</li> </ul>
Slow movements, unstable regulation.	<ul style="list-style-type: none"> <li>• Implement auto-tuning.</li> <li>• Increase the deadband (Tuning menu).</li> <li>• Adjust Performance (Calibrate menu).</li> </ul>

## 11. Technical data

Rotation angle	min 25° max 100°
Stroke	From 5 mm (0.2")
Input signal	4-20 mA DC
Air supply	1.4-6 barg (20-85 psi) DIN/ISO 8573-1 3.2.3 Free from oil, water and moisture.
Air delivery	7 Nm <sup>3</sup> /h @ 6 bar / 4.12 SCFM @ 87 psi
Air consumption	0.120 Nm <sup>3</sup> /h @ 6 bar / 0.071 SCFM @ 87 psi
Air connections	1/4" NPT
Cable entry	2x M20x1.5 or 1/2" NPT
Electrical connections	Screw terminals 2.5 mm <sup>2</sup> /AWG14
Linearity	<0.4%
Repeatability	<0.5%
Hysteresis	<0.3%
Dead band	0.1-10% adjustable
Display	Graphic, view area 15 x 41 mm (0.6 x 1.6")
UI	5 push buttons /single push button
CE directives	93/68EEC, 2014/30/EU, 92 /31/EEC
Voltage drop, w/o HART	8 V
Voltage drop, with HART	9.4 V
Enclosure	IP66
Material	Die-cast Aluminum
Surface treatment	Powder coating
Temperature range	-20°C to 85°C (-4°F to 185°F)
Weight	1.8 kg (4 lbs)
Mounting position	Any
Communication protocols	Hart, Profibus PA, Foundation Fieldbus

<i>Mechanical switches</i>	
Type	SPDT
Size	V3
Rating	3 A/250 VAC / 1A@30VDC
Temperature range	-40°C to 80°C (-40°F to 180°F)

<i>NAMUR sensors</i>	
<i>(NJ2-V3-N)</i>	
Type	Proximity DIN EN 60947-5-6:2000
Load current	1 mA ≤ I ≤ 3 mA
Voltage range	8,2 VDC
Hysteresis	0.2%
Temperature range	-25°C to 85°C (-13°F to 185°F)

<i>Proximity switches</i>	
Type	SPDT
Rating	0.4 A @ 24 VDC, Max 10 W
Operating time	Max 1.0 ms
Max voltage	200 VDC
Contact resistance	0.2 Ω
Temperature range	-40°C to 80°C (-40°F to 180°F)

<i>Slot NAMUR switches</i>	
<i>(SJ2-SN, SJ2-N)</i>	
Type	Proximity DIN EN 60947-5-6:2000
Load current	1 mA ≤ I ≤ 3 mA
Voltage	8,2 VDC
Hysteresis	0.2%
Temperature range	-25°C to 85°C (-13°F to 185°F) SJ2-N -40°C to 85°C (-40°F to 185°F) SJ2-SN

<i>4-20 mA transmitter</i>	
Supply	11-28 VDC
Output	4-20 mA
Resolution	0.1%
Linearity full span	+/-0.5%
Output current limit	30 mA DC
Load impedance	800 Ω @ 24 VDC

# 12. Dimensional Drawing

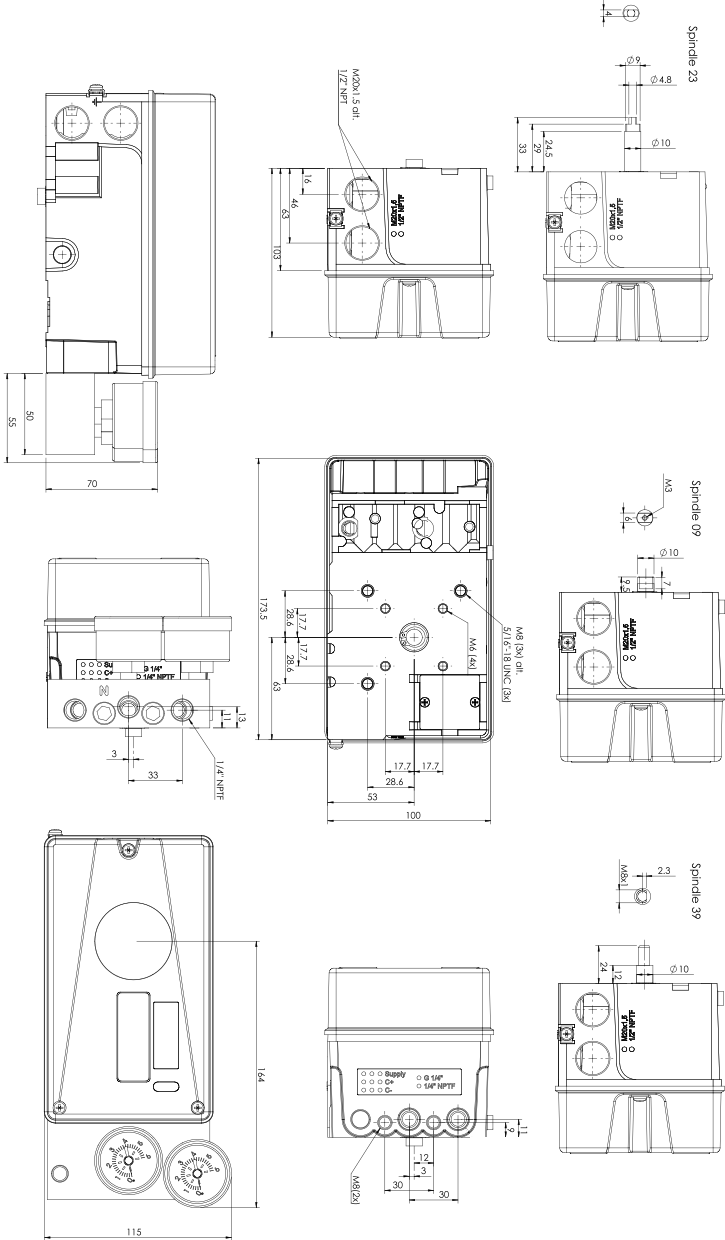

## 13. Spare parts

No	Part no	Description
1	D4-SP37PVA	Black cover incl. screws and flat indicator
1	D4-SP37FWA	White cover incl. screws and flat indicator
2	D4-SP40	Internal cover incl. screws
3	D4-SP1516	External covers SST, 2, incl screws
4	3-SXX	Spindle adaptor (XX = 01, 02, 06, 26, 30, 36...)
5	D4-SP05-09	S09 shaft compl. incl. gear wheel, friction clutch, spring
5	D4-SP05-21	S21 shaft compl. incl. gear wheel, friction clutch, spring
5	D4-SP05-23	S23 shaft compl. incl. gear wheel, friction clutch, spring
5	D4-SP05-39	S39 shaft compl. incl. gear wheel, friction clutch, spring
6	D2-SP50 STD	Air relay complete, incl. cable, seal, screws
7	D4-SP08	Potentiometer compl. incl. spring, bracket, cable
8	3-SP37HR	PCB LCD, 5 buttons, assembly
8	AV-SP080	PCB LCD only, assembly
9	D4-SP80-3S	PCB mother board 4-20 mA / HART (For D22 version)
9	D4-SP80-1S	Single button PCB mother board 4-20 mA / HART
9	D4-SP80-PS	PCB mother board Profibus PA
9	D4-SP80-FS	PCB mother board Fieldbus
10	D4-SP84-2	D20 pressure sensor assembly complete (Optional)
11	D4-SPGB	Bag with screws, O-rings, seals, pair of sintered brass silencers, cable gland
12	D4-SP940N2	Gauge block G, complete incl. screws, seals, 2 gauges / SST, Brass
13	D4-SP081 S	Limit switches Mechanical SPDT compl.
13	D4-SP081 N	Limit switches Namur V3 P&F NJ2-V3-N compl.
13	D4-SP081 P	Limit switches Proximity SPDT compl.
13	D4-SP081 5	Limit switches Namur slotted P&F SJ2-SN compl.
13	D4-SP081 6	Limit switches Namur slotted P&F SJ2-N compl.

**Note:** Replacement of certified spare parts require proper qualification and knowledge of applicable standards.

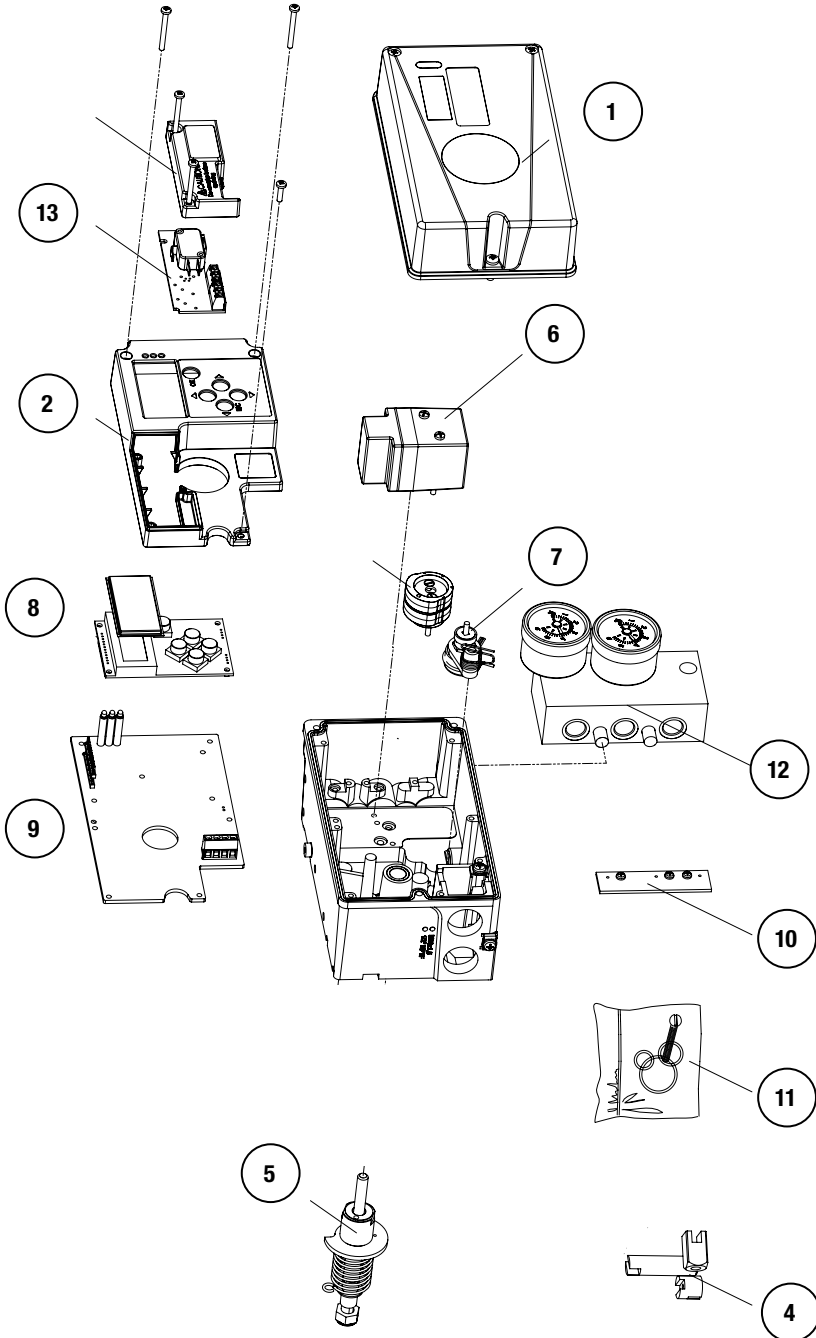

## 14. Applied Standards

---

EN 61000-6-2 C1	2005-09-26
EN 61000-6-3 A2	2007-02-26
EN 61000-6-4 A1	2007-02-26
EN 60204-1 A1	2007-05-21
IEC 61010-1	2010
EN IEC 60079-0:2018	2012+A11:2013
EN 60079-11	2012
EN 60079-14	2014
EN 60079-26	2015
EN 60079-27	2010
IEC 61158-2	2014



# 15. Control Drawing

### D30/D20 series terminal configuration

(Position J, J=4 or 5)  
(Position J, J=4 or 5)

**4-20mA input signal** Pin 1 and 2  
Position J, J=4 or 5

HAZARDOUS AREA UNCLASSIFIED AREA

1+ POSITIONER  
U 5 ± 28 V  
I 5 ± 83 mA  
C 5 ± 11.3 nF  
L 5 ± 10 µH

2- Safety Barrier

HAZARDOUS AREA UNCLASSIFIED AREA

1+ POSITIONER  
U 5 ± 7.5 V  
I 5 ± 300 mA  
P 5 ± 5.32 W  
C 5 ± 5 nF  
L 5 ± 10 µH

2- Safety Barrier

HAZARDOUS AREA UNCLASSIFIED AREA

**4-20mA Output signal** Pin 3 and 4  
(Position J, J=4 or 5) AND (Position K; K≠X)

HAZARDOUS AREA UNCLASSIFIED AREA

3+ POSITIONER  
U 5 ± 28 V  
I 5 ± 83 mA  
P 5 ± 6.53 W  
C 5 ± 22 nF  
L 5 ± 11.3 µH

4- Safety Barrier

HAZARDOUS AREA UNCLASSIFIED AREA

**Remote Unit**

Position GG; GG≠X (Where X any character) (Unit has no switches)

HAZARDOUS AREA UNCLASSIFIED AREA

POSITIONER  
Po 0.38W

8 Potentiometer of FS unit

9

10

Requires shielded cable less than 10 m or 30 feet

Potentiometer unit needs an appropriate and compatible Certification for the Hazardous area

Allowed FS units are: F5ISxx-xxx-P07-xxP/xxxx  
F5ISxx-xxx-P18-xxP/xxxx; F5ISxx-xxx-P27-xxP/xxxx

### D30 Model code

1 2 3 4 5 6 7 8 9 10 11 12 13 14 15 16 17 18 19

**A A B C D E - F G H I J - K L M N**

Position D designates certification

Position J designates communication protocol

Position N designates switch type

Position H 13 designates indicator type

General	
D	Imetro
B	Imetro
K	Ksiba
T	TR-CLU
A	ATEX
E	IEC
F	FM/IS/NI

Pos.B

switches	
HAZARDOUS AREA UNCLASSIFIED AREA	
Switch U, J, P and L	
5 or 8	According to table
5 or 9	7 or 10
Safety Barrier	

terminal 7 and 10 not used for Namur Switches  
Terminal 5-7 lower switch  
Terminal 8-9 upper switch

### D30 Model code

1 2 3 4 5 6 7 8 9 10 11 12 13 14 15 16 17 18 19

**A A B C D E - F G H I J - K L M N**

Position D designates certification

Position J designates communication protocol

Position N designates switch type

Position H 13 designates indicator type

General	
D	Imetro
B	Imetro
K	Ksiba
T	TR-CLU
A	ATEX
E	IEC
F	FM/IS/NI

Pos.B

switches	
HAZARDOUS AREA UNCLASSIFIED AREA	
Switch U, J, P and L	
5 or 8	According to table
5 or 9	7 or 10
Safety Barrier	

terminal 7 and 10 not used for Namur Switches  
Terminal 5-7 lower switch  
Terminal 8-9 upper switch

### ATEX, IEC, cFMus

**Warnings:**  
Substitution of components may impair suitability for hazardous (Classified) locations. Do not disconnect equipment unless area is known to be non-hazardous.  
To prevent ignition of flammable or combustible atmospheres, disconnect power before servicing, or read, understand and adhere to the manufacturer's line maintenance procedures.  
Avoid intensive rubbing or brush charging of plastic parts in combustible atmospheres.

**Avertissement:**  
La substitution de composants peut compromettre la sécurité intrinsèque. Ne déconnectez pas l'équipement tant que la zone n'est pas dangereuse.  
Pour éviter l'inflammation des atmosphères inflammables ou combustibles, débranchez l'alimentation avant de procéder à l'entretien, ou, lire, comprendre et respecter les procédures de maintenance en direct du fabricant.  
Éviter de frotter ou de charger à la brosse des pièces en plastique dans des atmosphères combustibles.

Special condition for safe use - see Sheet page 2

### model code position K

Note	SWITCH	Type	CirF	LUH	UV	I mA	Pi nW	MH Temp	T4	T5	T6	T ATEX id	E IECEx id	F FM (S/NL)
5	2.4	SZ-SH	30	100	16	25	34	40	96	68	56	100	Gc	S/NL
6	1.4	SZ-N	30	100	16	25	34	25	96	68	56	100	Gc	S/NL
7	1	SCZ-ND-SN	130	150	16	25	34	25	95	67	55	100	Gc	Gc
8	1	SCZ-ND-E	130	150	16	25	34	25	95	67	55	100	Gc	Gc
9	1	MISC. (MISCELLANEOUS SWITCH GOOD)	1	20	45	315	40	75	60	45	100	Gc	S/NL	Gc
N	3.4	IND-Z-VN (INDICATOR WITH VIBRATION)	40	50	16	25	34	25	96	68	56	100	Gc	S/NL
G	3.4	IND-Z-VN (INDICATOR WITH VIBRATION)	1	20	45	315	40	75	60	45	100	Gc	S/NL	Gc
L	3.4	IND-Z-VN (INDICATOR WITH VIBRATION)	1	20	45	315	40	75	60	45	100	Gc	S/NL	Gc
U	3.4	IND-N-V-240 (INDICATOR WITH VIBRATION)	100	100	12	25	34	25	73	88	100	Gc	Gc	S/NL

note 1 ATEX IEC: Higher U, L and P with lower ambient temperatures are allowed see Certificate PIB 99 ATEX 2219 X or IECEx PIB 11.0091 X  
note 2 ATEX IEC: Higher U, L and P with lower ambient temperatures are allowed see Certificate PIB 00 ATEX 2049 X or IECEx PIB 11.0092 X  
note 3 ATEX IEC: Higher U, L and P with lower ambient temperatures are allowed see Certificate PIB 00 ATEX 2032 X or IECEx PIB 11.0021 X  
note 4 cFMus: For safe S installation and alternative safety values, see FM control drawing: 116-01655 - and for NI installation without associated apparatus see control drawing: 116-0155E.

### model code position B

ATEX id	IECEx id	FM (S/NL)
100	100	100
16	16	16
25	25	25
34	34	34
40	40	40
56	56	56
68	68	68
96	96	96
100	100	100

### Scheduled drawing

No modification permitted without reference to notified body

**Control Drawing**

DESCRIPTION: UNCLASSIFIED AREA

MATERIAL: UNCLASSIFIED AREA

UNDESIGNED TOLERANCES ACCORDING TO: SURFACE

PROJECTION: UNCLASSIFIED AREA

SCALE: 4

DATE: 2017-12-11

**PMV Positioners D30/D20**

PMV Automation AB  
KORTA GATAN 9 SE-171 14 SÖDRA SVEBEN - Tel: +46(0)8 555 106 00 - www.pmv.se

Sheet 1.2

**FM only**

**HAZARDOUS AREA:**  
 Class I, II, Division 1, Group A, B, C, D, T4  
 Class I, Zone 0, 1, AEx, ia, IIC, T4  
 Class I, Division 2, Group A, B, C, D, T4  
 Class II, Div. 1, AEx, ia, IIC, T4  
 Class II, Div. 1&2, T4

**INSTALLATION NOTES:**

- Control equipment connected to the associated apparatus shall not use or generate more than 250Vrms or Vdc.
- Associated apparatus manufacturer's installation drawing shall be followed when installing this equipment.
- Run shielded interconnection cable with shield connected to FM approved associated apparatus ground.

**The intrinsically safety entity concept:**

Allows the interconnection of two intrinsically safe devices FM approved with entity parameters not specifically examined in combination as a system when:  
 Uo or Voc or Vi ≤ Vmax, Io or Iac or I<sub>s</sub> ≤ Imax, Po ≤ Pi, Co or Co ≥ Ci + Ccable, La or Lo ≥ Li + Lcable.

**The non-inductive field wiring concept:**

Allows the interconnection of two field wiring apparatus with associated non-inductive field apparatus, using any of the wiring methods permitted for non-hazardous (undclassified) locations when:  
 Uo or Voc or Vi ≤ Vmax, Io or Iac or I<sub>s</sub> ≤ Imax, Po ≤ Pi, Co or Co ≥ Ci + Ccable, La or Lo ≥ Li + Lcable.

**The non-inductive:**

- Use IS values as general (Vmax = Ui ; Imax = Ii) except for following:
- Nameplate Vmax = 250V, Imax is not required for this current controlling circuit
- Proximity Switch (Pos Kc-F)  
 Vmax = 30V ; Imax = 500mA  
 4-20mA input signal ( P in 1 and 2)  
 Vmax= 30V ; Imax =40mA
- 4-20mA Output signal ( P in 3 and 4)  
 Vmax= 30V ; Imax is not required for this current controlling circuit

**For division 1 installations:**

- The configurations of associated apparatus shall be FM approved under entity concept.
- Division1 installations should be in accordance with ASH/ISA RP12.06.01
- Installation of intrinsically safe systems for hazardous (classified) locations\* and the national electrical code (ANSI/NFPA 70).

**For division 2 installations:**

- Using non-inductive field wiring concept, the associated apparatus shall be FM approved under entity concept or non-inductive field wiring concept.
- The associated apparatus is not required to be FM approved under entity concept or non-inductive field wiring concept if the unit is installed in accordance with the national electrical code (ANSI/NFPA 70) for division 2, wiring methods including non-inductive field wiring.

**ATEX IEC**  
 (Including IEC related Certificates)

**Special Conditions for Safe Use**

The enclosure of PMV D30/D20 Intrinsically safe version is made of aluminum and any impact or friction caused by external objects shall be avoided in the application.

The intrinsic safe circuits D30(D20) is insulated from earth and complies with the dielectric strength test of 500 V ac.

The surface area of the plastic parts on the cover exceeds the limits specified in EN 60079-0 for II TG (EPL Ga) for gas group IIC and intensive rubbing or brush cleaning should be avoided when used in an IIC explosive atmosphere.

The cable connection of the Remote Unit with the D30(D20) unit shall be type A or B in accordance with EN 60079-26. The cable must be adequately mechanically protected in all instances and have a temperature rating for the ambient temperature range at the site.

**General requirements for units with 4 conduit openings and NPT threading.**  
**Model code position D=N and Position E= 4 or F**

Cable glands must be used when installing.  
 Cable glands may not be installed on the same level.  
 A maximum of two cable glands may be used, the unused openings must be plugged by supplied blanks or other suitable blanks.

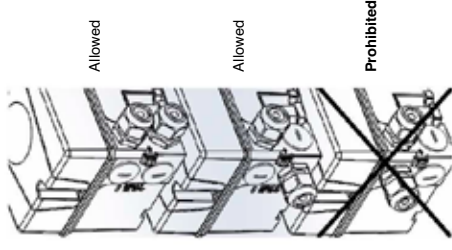

Sheet 2.2

DESCRIPTION	MATERIAL	DIMENSION	AMOUNT
Control Drawing	UNSPECIFIED TOLERANCES ACCORDING TO:	PROJECTION EUROPA	
FILE NO.		DR BY	SCALE
		LRW	4
		Rev.	—
		DATE	2017-12-11
		DRAWING NO.	
			D4-086C
			PMV Automation AB
			KORTA GATAN 9 SE-171 84 SOMMA SVEDEEN - TEL: +46(0)8 555 108 00 - WWW.PMV.AB

**Scheduled drawing**  
 No modification permitted without reference to National Body

REV.	DESCRIPTION	REVISIONS	DATE	BY
1	AS PER IEC 61508-1:2010 (SIL 1) and IEC 61508-2:2010 (SIL 2) wiring added. Cable gland in electric box added.		2019-04-29	LRW
2	ATEX and IEC RECO related information updated.		2019-09-18	LRW
3	Changes to drawings to add the following: Special added certification table		2019-11-19	LRW
4	Special condition for ATEX IEC updated Q value		2020-03-10	LRW

This document must not be copied without our written permission and the contents thereof must not be imparted to a third party nor be used for any unauthorized purpose. Copying without our written permission is prohibited.





**PMV Automation AB**  
Korta Gatan 9  
SE-171 54 SOLNA  
SWEDEN  
Phone: +46 (0)8-555 106 00  
E-mail: [infopmv@flowserve.com](mailto:infopmv@flowserve.com)

**PMV USA**  
1511 Jefferson St. East  
Sulphur Springs, TX 75482  
Phone: +1 281 671 9209  
Fax: +1 281 671 9268  
E-mail: [pmvsales@flowserve.com](mailto:pmvsales@flowserve.com)

**Flowserve Flow Control**  
Burrell Road, Haywards Heath  
West Sussex RH16 1TL  
Phone: +44(0)1444 314400

**Flowserve Flow Control Benelux**  
Rechtzaad 17  
4703 RC Roosendaal  
THE NETHERLANDS  
Phone: +31 (0) 30 6771946  
Fax: +27 (0) 30 6772471

**Flowserve Flow Control GmbH**  
Rudolf-Plank Strasse 2  
D-76275 Ettlingen  
GERMANY  
Phone: +49 (0) 7243 103 0  
Fax: +49 (0) 7243 103 222

**Flowserve Corporation**  
No. 35, Baiyu Road  
Suzhou Industrial Park  
Suzhou 215021, Jiangsu Province,  
PRC  
Phone: +86-512-6288-1688  
Fax: +86-512-6288-8737

**Flowserve (China)**  
585, Hanwei Plaza  
7 Guanghau Road  
Beijing, China 100004  
Phone: +86 10 6561 1900

**Flowserve Pte Ltd**  
No. 12 Tuas Avenue 20  
Singapore 638824  
Phone: +65 6879 8900  
Fax: +65 6862 4940

**Flowserve do Brasil Ltda**  
Rua Tocantins, 128 - Bairro Nova Gerti  
São Caetano do Sul,  
São Paulo 09580-130 Brazil  
Phone: +5511 4231 6300  
Fax: +5511 4231 6329 - 423

## FCD PNENIM0020-06-A5 – 07/24

To find your local Flowserve representative:

To find your local Flowserve representative  
please use the Sales Locator

System found at [www.flowserve.com](http://www.flowserve.com)

Flowserve Corporation has established industry leadership in the design and manufacture of its products. When properly selected, this Flowserve product is designed to perform its intended function safely during its useful life. However, the purchaser or user of Flowserve products should be aware that Flowserve products might be used in numerous applications under a wide variety of industrial service conditions. Although Flowserve can provide general guidelines, it cannot provide specific data and warnings for all possible applications. The purchaser/user must therefore assume the ultimate responsibility for the proper sizing and selection, installation, operation, and maintenance of Flowserve products. The purchaser/user should read and understand the user instructions included with the product, and train its employees and contractors in the safe use of Flowserve products in connection with the specific application.

While the information and specifications contained in this literature are believed to be accurate, they are supplied for informative purposes only and should not be considered certified or as a guarantee of satisfactory results by reliance thereon. Nothing contained herein is to be construed as a warranty or guarantee, express or implied, regarding any matter with respect to this product. Because Flowserve is continually improving and upgrading its product design, the specifications, dimensions and information contained herein are subject to change without notice. Should any question arise concerning these provisions, the purchaser/user should contact Flowserve Corporation at any one of its worldwide operations or offices.

For more information about Flowserve Corporation, contact [www.flowserve.com](http://www.flowserve.com) or call USA 1-800-225-6989.

© July 2024, Flowserve Corporation, Irving, Texas