

F5 Switch Box

PMENIM0005-07-A5 06/19

**Installation
Operation
Maintenance**



Contents

1. Introduction	3
2. Storage	4
3. Mounting on P5 or EP5	7
4. Mounting on P-2000/P-2020	8
5. Installing F5-EX on P5/EP5	9
6. Installing on an actuator	9
7. Calibration	11
8. Switches & Sensors	11
9. Connection of F5 intrinsically safe version	13
10. Spare Parts	14
11. Dimension drawing	15
12. Trouble shooting	16

1. Introduction

The PMV F5 is a feedback unit uniquely designed to mount on top of the PMV P5, EP5 or P-2000 positioners with minimum parts required. The F5 can also be mounted on actuators with an additional mounting kit. The F5 is available in two different enclosures, standard or explosion proof.

The standard enclosure for F5 offers a gasketed enclosure with optional American and European intrinsically safe approvals. The explosion proof version carries North American and European approvals. Both enclosures can be furnished with Namur sensors, mechanical or proximity switches, potentiometer or 4-20 mA position transmitter or a combination of these items.

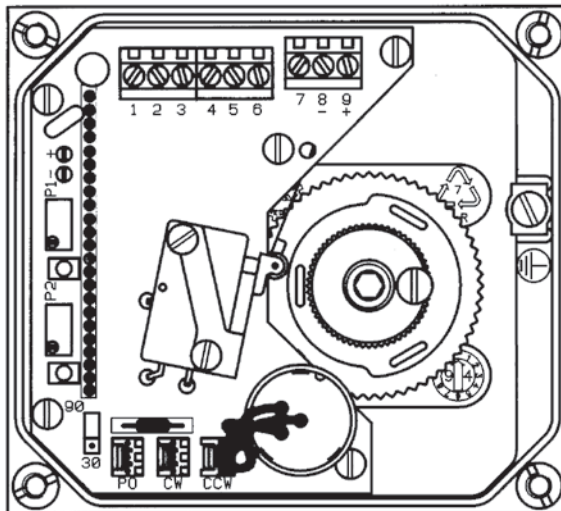

**Warning!***Special Conditions for Safe Use*

The enclosure of PMV F5 Intrinsically Safe version is made of aluminum and any impact or friction caused by external objects shall be avoided in the application.

The various circuits of the electrical apparatus must only be connected to intrinsically safe certified electrical apparatus, and these combinations must be compatible with the rules of intrinsic safety.

The various circuits may be considered as separated if none of the voltages applied exceeds 30 V.

F5 Explosion proof

The flameproof joints are not intended to be repaired.





The special fasteners of the cover on the body are composed of 8 screws stainless steel 6H M6x16. The minimum property class of screws must be A2 70. The screws must be replaced with identical ones.

Type sign example

F5-XXX FEEDBACK UNIT
 INTRINSICALLY SAFE / SECURITE INTRINSEQUE-Exia

Ex ia IIC T4 Ga Cl.I Div1 Groups C-D T3C
 Electrical rating: 28V DC, 24mA

When installed in accordance with installation drawing: F5-2-4-9516
WARNING! Substitution of components may impair intrinsic safety.
AVERTISSEMENT! La substitution de composants peut compromettre la securite intrinseque.
 Potential electrostatic charging hazard - See instruction.

LCIE 03ATEX 6103X   II 1G  



XXXXX

PMV AUTOMATION AB
 SOLNA, SWEDEN



Prod.year-Serial number

EXPLOSION PROOF FEEDBACK UNIT F5EX-XXX*

Class I,Div.1,Grps B-D, Class II,Div.1,Grps E-G, Class III
 T6(T_{amb}+50°C) T5(T_{amb}+60°C) T4(T_{amb}+80°C)
 Electrical rating: According to table.

APPROVED

Ex db IIB+H, Gb T6(T_{amb}+50°C) T5(T_{amb}+60°C)
  II 2G
 LCIE 03ATEX 6137X
 Electrical rating: According to table

XXXXX

DO NOT OPEN WHILE ENERGIZED! / NE PAS OUVRIER SOUS TENSION!
TORQUE COVER BOLTS TO / TORQUE BOULONS DE COUVERTURE POUR: 5.2 lb*ft / 7Nm
WARNING - POTENTIAL ELECTROSTATIC CHARGING HAZARD! TO AVOID ELECTROSTATIC HAZARD, CLEAN THE DEVICE WITH A WET CLOTH.
 - SEE INSTRUCTIONS!

Prod.year-Serial number

PMV AUTOMATION AB, SOLNA SWEDEN

2. Storage

PMV feedback modules are precision instruments which should be stored and handled accordingly to avoid problems or damage. Feedback modules contain electronic components which can be damaged by exposure to water. Appropriate precautions should be taken to protect units while in storage.

Warehouse storage

- Stored in original PMV shipping containers, units should be stored in an environmentally controlled area, i.e. clean, cool (15-26°C, 60-80°F) and dry, out of direct sunlight or weather exposure.

Field storage

- If feedback units must be stored outdoors, make sure front covers are tightened, all conduits entries are sealed and that units not are exposed to direct sunlight, rain or snow.

Potential damage mechanism

When units are stored in hot, humid climates, the daily heating/cooling cycle will cause air to expand/contract and be drawn in and out of the feedback housing through ports left open. Dependent on the local temperature variations, humidity and dew points and time in storage, condensation could occur and accumulate inside causing erratic operation or failure due to water and corrosion. The potential for condensation damage is especially high in southern climates and aggravated if units are exposed to direct sunlight.

For further assistance, please contact you nearest PMV office.

Storage Seal

F5 is supplied with conduit entry points sealed. The seal is only a storage seal, not to be used as seal when F5 is in operation.

If Storage Seal is removed or damaged, make sure conduit entry points are resealed before further shipping or storage.

Use proper cable glands or vapour proof tape.

Mount F5 on positioner P5/EP5 or actuator/valve package. Remove Storage Seal for conduit entry E1 & E2, make electrical connections, install proper cable glands or plugs to ensure the units sealing.

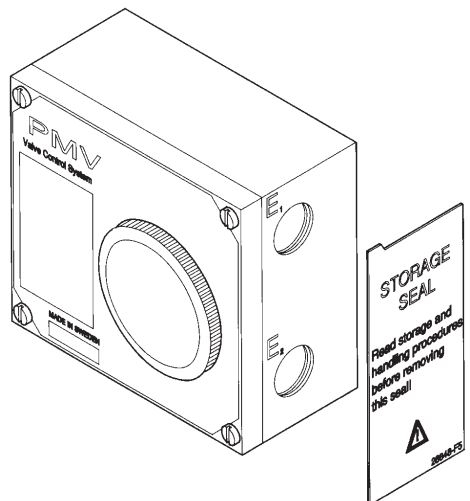

3. Mounting on P5 or EP5

- See www.pmv.nu/downloads for video clip.
- Remove the front cover and the indicator from the positioner.
- Loosen and remove the Allen head screw (3) (5mm hex-wrench)
- Install drive coupling (4) on the positioner shaft, secure it with screw (3)
- Check that F5 is fitted with 4 nos of screws (5) and O-ring (9), install the F5 on top of the positioner unit, make sure that the coupling is properly engaged before tightening the four screws (5)
- Make connections and calibrate.
- Reinstall indicator (2) and front cover (1) on the F5, tighten 1,5-2 Nm

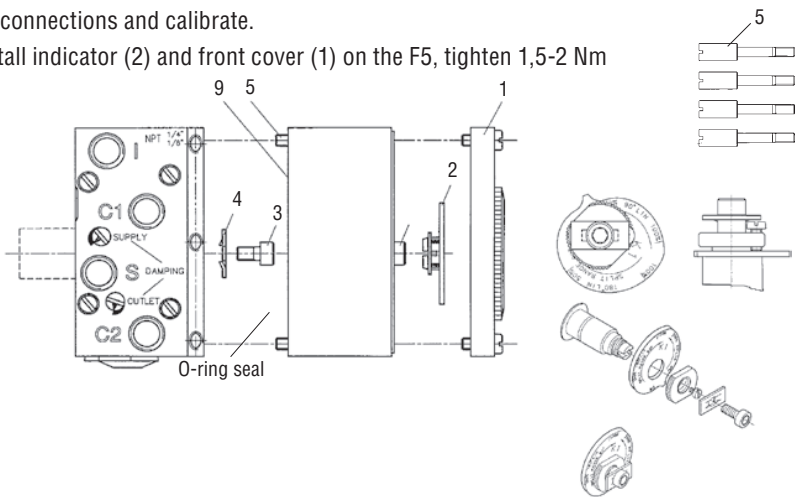

Mounting F5 on actuator (On/Off control valves)

Install the spindle adaptor (1) into F5 shaft, make sure that a spring clip (2) is fitted. A solid click should be heard when the spindle adaptor is properly installed into the F5 shaft.

Mount F5 on the actuator using a mounting kit and the ISO F05 mounting holes on the bottom of the F5. Make sure that the F5 spindle is properly aligned on top of the actuator.

Check that the four fasteners (3) are installed into F5.

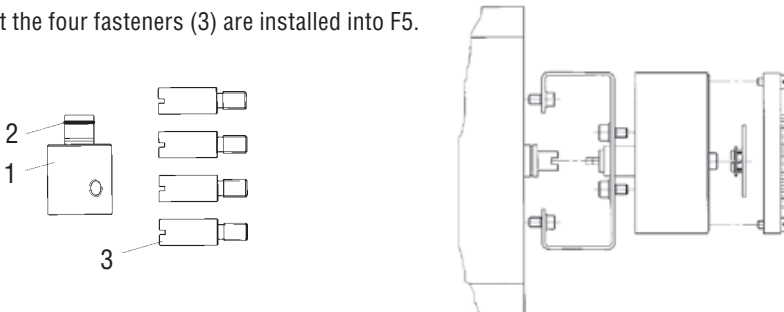

4. Mounting on P-2000/P-2020

- Remove front cover, indicator and cam nut from the positioner
- Replace the cam nut with coupling (1), calibrate the positioner.
- Check that the gasket is fitted to the bottom of plate (2), install screws (5) (3x long, 1x short) plastic washer (6) and O-rings (7).
- Secure the F5 to the plate (2) with screws (3).
- Install assembly on to the positioner, make sure that coupling (1) is properly engaged.
- Make electrical connections and calibrate.

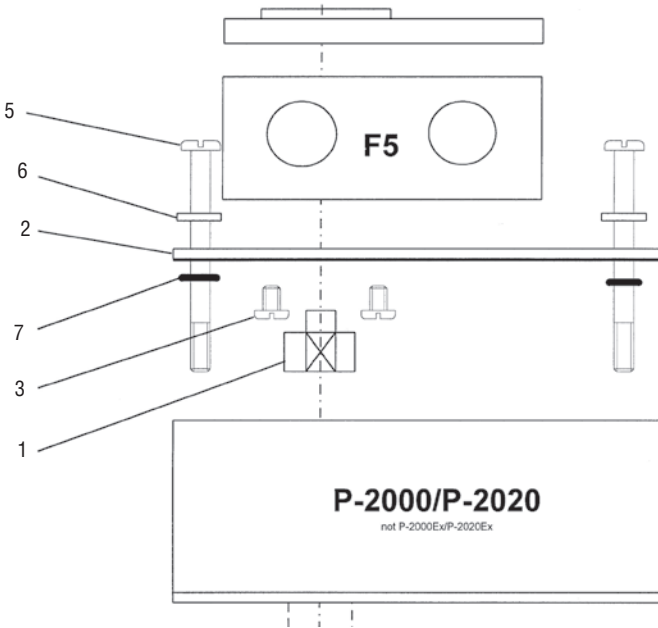

5. Installing F5-EX on P5/EP5

- See www.pmv.nu/downloads for video clip.
- Remove front cover, indicator and Allen head screw from the positioner.
- Install drive coupling (4) and secure it with the Allen head screw.
- Remove front covers and indicator from the F5-EX unit.
- Remove screws (3).
- Install F5-EX on P5/EP5, make sure drive coupling is properly engaged before tightening screws (5).
- Reinstall and tight screws (3). Connect and calibrate.
- Reinstall front covers and indicator.
- Front cover screws (2) shall be tightened to 7 Nm (5,2 lbf x ft)

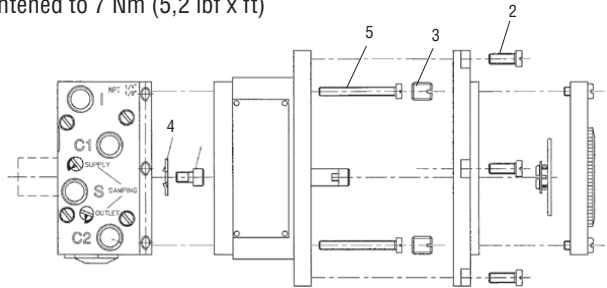

6. Installing on an actuator

- Remove front covers and indicator from the F5-EX unit.
- Install drive shaft into F5-EX, a solid click should be heard when spindle adapter is properly installed.
- Mount F5-EX on the actuator using the F05 holes and a mounting kit.
- Connect and calibrate, reinstall front covers and indicator.
- Front cover screws (2) shall be tightened to 7 Nm (5,2 lbf x ft).

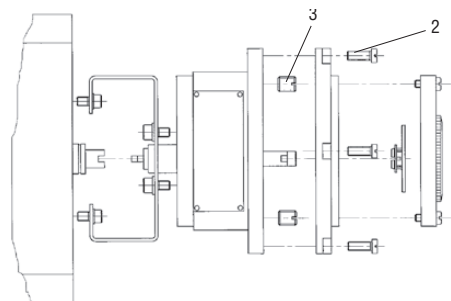

Connections

Conduit entries are PG13,5 (M20) or NPT 1/2"

Make electrical connections according to wiring diagrams and tighten cable glands. Terminals are 2.5 mm² (AVG 14) screw terminals.

Adjustments

CAUTION! Moving parts – risk of injury.

The cams/gear wheel are secured in position by friction provided from the cam/shaft assembly. To adjust switches and/or position transmitter, rotate gear wheel (2) and cams (3) to desired position using tool F5-22 or tip of a screw driver that fits snugly in one of the slotted holes. Start calibration procedure by adjusting position transmitter first, then continue with the lower switch and complete with the upper switch.

If cams exhibit high stiction, rotate them back and forth rapidly several times. Do not adjust nut (4) or lubricate cams, call PMV for assistance.

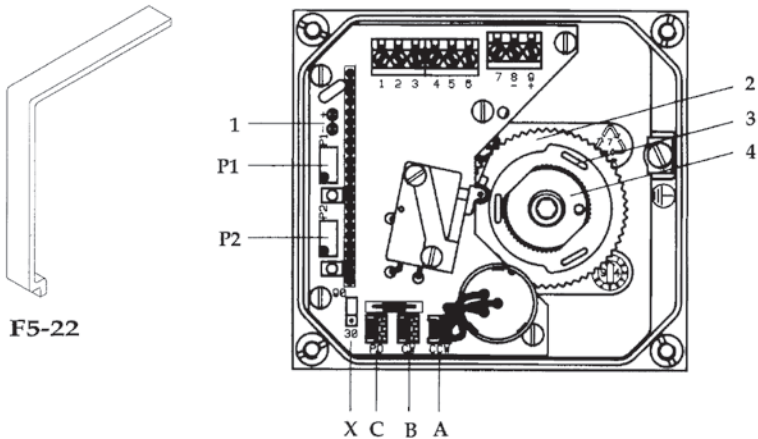

7. Calibration

4-20 mA position transmitter

Instruction video available on www.pmv.nu/downloads

1. Set direction of rotation by placing potentiometer jumper in location A or B. (Location A for counter clockwise CCW valve/actuator rotation (Direct), location B for clockwise CW valve/actuator rotation (Reverse)).
2. Set jumper X to the desired valve rotation angle, for 30 deg or 45 deg rotation choose position 30, For 60 deg or 90 deg rotation choose position 90, for 180 deg rotation choose position 30 and for 270 deg rotations choose position 90. For 30° deg - 45° deg choose pos 30.
3. Make electrical connections according to wiring diagram. Power supply should be >9 to <28 VDC (24 VDC recommended).
4. Connect a 4-20 mA meter to testoutlet 1. Adjust potentiometer P1 20 revolutions CW & P2 20 revolutions CCW. Stroke actuator to the desired 4 mA position and check that current deflection is correct. Rotate gear wheel 2 with tool F5-22 or tip of a screw driver placed in one of the slotted holes until minimum value is reached.
5. Adjust the output signal 4,0 mA with potentiometer P2. LED will illuminate when out put is 4 mA ($\pm 1\%$) or less. Stroke actuator to the desired 20 mA position and adjust the output to 20,0 mA with potentiometer P1. LED will illuminate when out put is 20 mA ($\pm 1\%$) or more.
6. Stroke actuator again, check and adjust 4 mA and 20 mA readings. Install front cover or set switches first, as follows:

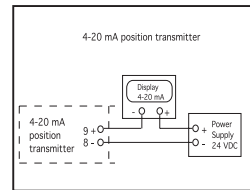

8. Switches & Sensors

Limit switches cams must be adjusted separately with valve in an open and closed position. With the valve in fully open or closed position adjust the lower cam 3 to desired position by rotating it with special tool F5-22 or by the tip of a screw driver placed in one of the slotted holes on the cam. Stroke the valve fully and repeat the procedure above to set the upper cam. Stroke valve open/closed to check proper limit switch operation.

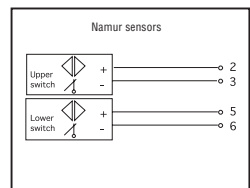
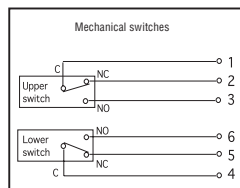
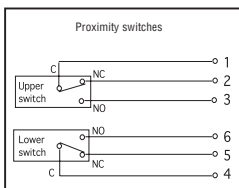

Potentiometer only (no transmitter function)

1. Make electrical connections to terminals 7, 8 and 9. Check that the potentiometer is connected to connector C on the printed circuit board.
2. Stroke the actuator to check direction of travel indicated by the potentiometer. To change direction of travel, swap wires at terminals 7 and 9.
3. Stroke the actuator to the position where the minimum potentiometer resistance is desired.
4. Adjust the potentiometer output reading to approx. 50 Ohm by rotating gear wheel 2 with special tool F5-22 or tip of a screw driver placed in one of the slotted holes.
5. Stroke the actuator to desired maximum resistance position and check reading.
6. Repeat steps 3-5 if necessary to obtain desired resistance change.
7. Set switches or install frontcover.

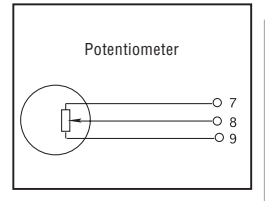

Technical specifications

General	
Conduit entries	2x 1/2" NPT or 2x M20x1.5
Enclosure F5/F5IS	Die cast aluminum
Enclosure F5EX	Chill cast aluminum
Surface treatment	Electrocoated
Fasteners	Stainless steel A2/A4
Terminals	2,5 mm ² (AVG 14)

Switches, mechanical	
Type	Mechanical SPDT V3
Rating	250VAC 6/2,5A
Approvals	CSA, UL, VDE
Temperature range	-40°C to 100°C (-40°F to 212°F)*

Switches Inductive Namur	
Type	Inductive Namur
Load current	≤ 1 mA ≥ 3 mA
Voltage range	5-25 VDC
Hysteresis	0,2%
Temperature range	-25°C to 85°C (-13°F to 185°F)*

Switches proximity	
Type	SPDT hermetically sealed
Contact rating	2 W or 2 VA @ 30 VDC/VAC, 0,1A
Breakdown voltage	200 VDC
Contact resistance	0,2 Ω
Operating lifetime	>10 million operations
Temperature range	-40°C to 105°C (-40°F to 221°F)*

Potentiometer	
Output	5 kΩ (4kΩ at 90°)
Elements	Conductive plastic
Power rating at 70°	1W
Linearity	1%
Resolution	Essentially infinite
Temperature range	-40°C to 125°C (-40°F to 257°F)*

4-20 mA position transmitter	
Power supply	9-28VDC (24VDC recommended)
Output signal	4-20 mA
LED indication at 4 mA	±1%
LED indication at 20 mA	±1%
Resolution	Infinite
Min. rotation travel	30°
Max. rotation travel	90°
Linearity	<1% of full scale
Hysteresis	<0,5% of full scale
Output current limit	24 mA DC
Load impedance	800 Ω at 24 VDC
Temperature range	-40°C to 80°C (-40°F to 176°F)

Weight	
F5/F5IS	0,7 kg (lbs 1,5)
F5EX	2,1 kg (lbs 4,6)

* Component temperature range may differ depending on approvals for hazardous locations.

9. Connection of F5 intrinsically safe version

Connection alternatives

Alt. 1
Mechanical switches
Not in combination
with alt. 2-5

Alt. 2
Mechanical switches

Alt. 3
Inductive Namur switches

Alt. 4
Potentialmeter

Alt. 5
4-20mA
Position transmitter

Hazardous area

Non hazardous area

CSA, FM approved safety barrier

③ **INSTALLATION INSTRUCTIONS FOR CLASS 1 DIVISION 2 VERSION:**

1. (For CSA) Install in accordance with the Canadian electrical code, part 1
2. To be connected without safety barriers.
3. Electrical ratings: See table below.

F5 TYPE	Connect- ion Alt.	HAZARDOUS AREA/CLASS 1 DIVISION 2	ELECTRICAL RATINGS	
			CL 1 DIVISION 2 Max VDC/Max mA	HAZARDOUS AREA Max VDC/Max mA
F5-SW/MEC	1	C/D	28	100
F5-SW/MEC	2	A,B,C,D, T6	28	100
F5-SW/MEC-420	2 + 5	C/D, T3C	28	100
F5-SW/MC-ROT	1 + 4	A,B,C,D, T6	15.5	32
F5-SW/MC-ROT	2 + 4	A,B,C,D, T6	15.5	32
F5-SW/NA	3 + 5	C/D, A,B,C,D, T6	28	100
F5-SW/NA-420	3 + 5	C/D, A,B,C,D, T6	28	100
F5-SW/NA-ROT	3 + 4	A,B,C,D, T6	28	100
F5-POT	4	A,B,C,D, T6	28	100
F5-420	5	A,B,C,D, T3C, A,B,C,D, T6	28	100
F5-SW/PHY	1	C/D, T6	28	100
F5-SW/PHY	2	A,B,C,D, T6	28	100
F5-SW/PHY-420	2 + 5	T3C, A,B,C,D, T6	28	100

Schedule drawing: [STHL 900/01-168-50-10](#)

① STHL 900/01-168-50-10

② STHL 900/51-280-091-14

③ STHL 900/01-280-050,085,100-10

④ STHL 925/02-10,20,40,60

10. Spare Parts

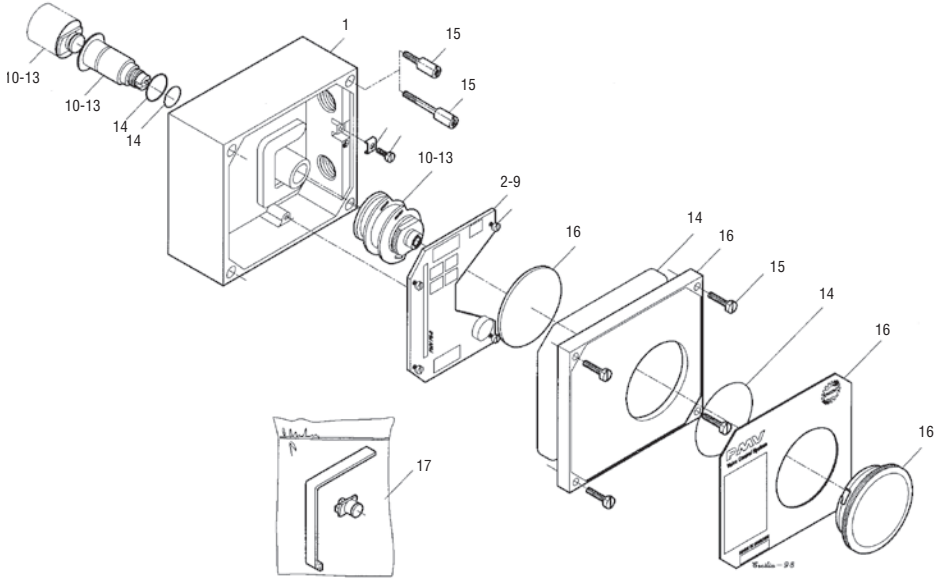

PMV can only offer spare parts for non-certified units.

DWG No	PMV Part no	Description	Qty	Set
1		Housing		
2	28176	PC board incl. 2 x Mechanical switches	1	
3	28177	PC board incl. 2 x Mechanical switches and potentiometer	1	
4	28178	PC board incl. 2 x Mechanical switches and 4-20 mA transmitter	1	
5	28179	PC board incl. 2 x Namur sensors	1	
6	28181	PC board incl. 2 x Namur sensors and 4-20 mA transmitter	1	
7	29272	PC board incl. 2 x Proximity switches	1	
8	29270	PC board incl. 2 x Proximity switches and potentiometer	1	
9	29271	PC board incl. 2 x Proximity switches and 4-20 mA transmitter	1	
10	29227	Cam & shaft assy for Mechanical switches or Namur sensors	1	
11	29275	Gam & shaft assy for Proximity switches	1	
12	29228	Cam & shaft assy for Mechanical switches or Namur sensors + transmitter	1	
13	29276	Cam & shaft assy for Proximity switches + transmitter	1	
14	F5-SEAL-NBR	Elastomer kil, itirile NBR		1
15	F5-SCREWS	Screw kil F5		1
16	F5-AS2-PV90	Fron cover assembly incl.flat indicator		1
17	F5-SP22	Coupling F5-S00 and Adjusting Tool FS-22		1

11. Dimension drawing

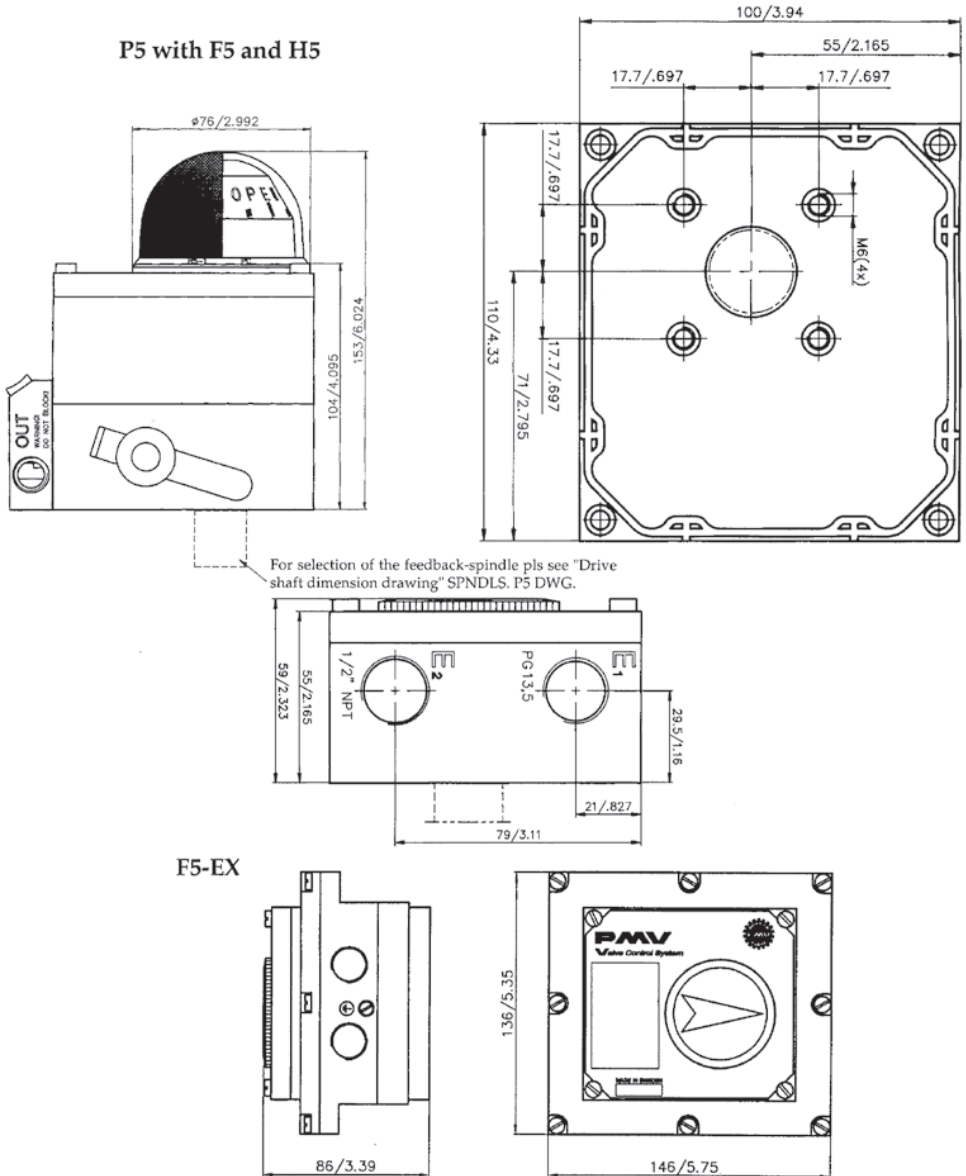

12. Trouble shooting

Switches

Check electrical connections and cam settings.

Potentiometer

If there is no output signal, check electrical connections and for open circuit, check that potentiometer is not out of its mechanical range.

If output deflection is wrong reverse connection terminals 7 and 9.

4-20 mA position transmitter

If there is no output signal, check electrical connections, polarity, loop power supply, and that the potentiometer is within its range.

If full output signal cannot be achieved by adjustment, check supply voltage and jumper X settings.

If output signal increases and decreases in the wrong direction, move connector from A to B or vice versa.

If the 4 mA fine adjustment P2 does not have enough span, zero must be mechanically realigned as follows: Turn P2 20 revolutions counter clockwise, then repeat the transmitter calibration procedure.



PMENIM0005-07-A5 06/19

To find your local Flowserve representative:

To find your local Flowserve representative please use the Sales Locator

System found at www.flowserve.com

Flowserve Corporation has established industry leadership in the design and manufacture of its products. When properly selected, this Flowserve product is designed to perform its intended function safely during its useful life. However, the purchaser or user of Flowserve products should be aware that Flowserve products might be used in numerous applications under a wide variety of industrial service conditions. Although Flowserve can provide general guidelines, it cannot provide specific data and warnings for all possible applications. The purchaser/user must therefore assume the ultimate responsibility for the proper sizing and selection, installation, operation, and maintenance of Flowserve products. The purchaser/user should read and understand the user instructions included with the product, and train its employees and contractors in the safe use of Flowserve products in connection with the specific application.

While the information and specifications contained in this literature are believed to be accurate, they are supplied for informative purposes only and should not be considered certified or as a guarantee of satisfactory results by reliance thereon. Nothing contained herein is to be construed as a warranty or guarantee, express or implied, regarding any matter with respect to this product. Because Flowserve is continually improving and upgrading its product design, the specifications, dimensions and information contained herein are subject to change without notice. Should any question arise concerning these provisions, the purchaser/user should contact Flowserve Corporation at any one of its worldwide operations or offices.

For more information about Flowserve Corporation, contact www.flowserve.com or call USA 1-800-225-6989.

© June 2019, Flowserve Corporation, Irving, Texas

PMV Automation AB

Korta Gatan 9
SE-171 54 SOLNA
SWEDEN
Phone: +46 (0)8-555 106 00
E-mail: infopmv@flowserve.com

PMV USA

14219 Westfair West Drive
Houston, TX 77041, USA
Phone: +1 281 671 9209
Fax: +1 281 671 9268
E-mail: pmvsales@flowserve.com

Flowserve Flow Control

Burrell Road, Haywards Heath
West Sussex RH16 1TL
Phone: +44(0)1444 314400
E-mail: pmvuksales@flowserve.com

Flowserve Flow Control Benelux

Rechtzaad 17
4703 RC Roosendaal
THE NETHERLANDS
Phone: +31 (0) 30 6771946
Fax: +27 (0) 30 6772471
E-mail: fbinfo@flowserve.com

Flowserve Flow Control GmbH

Rudolf-Plank Strasse 2
D-76275 Ettlingen
GERMANY
Phone: +49 (0) 7243 103 0
Fax: +49 (0) 7243 103 222
E-mail: argus@flowserve.com

Flowserve Corporation

No. 35, Baiyu Road
Suzhou Industrial Park
Suzhou 215021, Jiangsu Province,
PRC
Phone: +86-512-6288-1688
Fax: +86-512-6288-8737

Flowserve (China)

585, Hanwei Plaza
7 Guanghau Road
Beijing, China 100004
Phone: +86 10 6561 1900

Flowserve Pte Ltd

No. 12 Tuas Avenue 20
Singapore 638824
Phone: +65 6879 8900
Fax: +65 6862 4940

Flowserve do Brasil Ltda

Rua Tocantins, 128 - Bairro Nova Gerti
São Caetano do Sul,
São Paulo 09580-130 Brazil
Phone: +5511 4231 6300
Fax: +5511 4231 6329 - 423